



Wrocław  
University  
of Science  
and Technology

# Engine and powertrain



HR EXCELLENCE IN RESEARCH

# Power to overcome by the engine

- ***gearing losses:***
  - friction losses, load-dependent,
  - churning and squeezing losses attributable to splash lubrication, load-independent,
- ***bearing losses:***
  - friction losses, load-dependent,
  - lubrication losses, load-independent,
- ***sealing losses:***
  - friction losses caused by rotary shaft seals at shaft exits,
  - friction losses caused by piston rings used to keep oil under pressure at the shift elements,
- ***synchronizing losses:***
  - fluid friction between synchronizer ring and friction cone,
- ***clutch losses:***
  - fluid friction with wet running, multi-plate clutches and brakes in automatic gearboxes and automated manual gearboxes,
- ***torque converter losses:***
  - losses in the hydrodynamic torque converter,
- ***auxiliary units:***
  - power to drive auxiliary unit

# Powertrain

- 1) Engine,
- 2) Clutch,
- 3) Gear box,
- 4) Cardan joint,
- 5) Differential,
- 6) Drive axle.

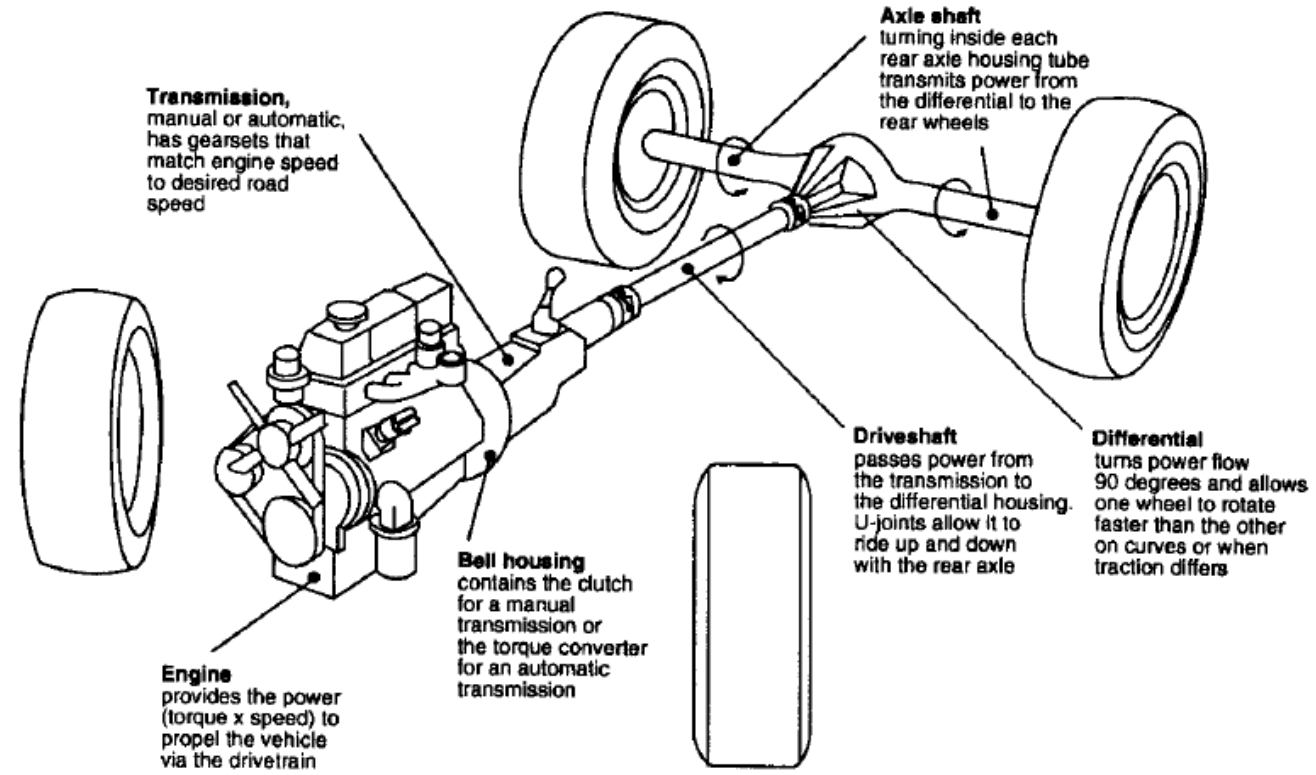
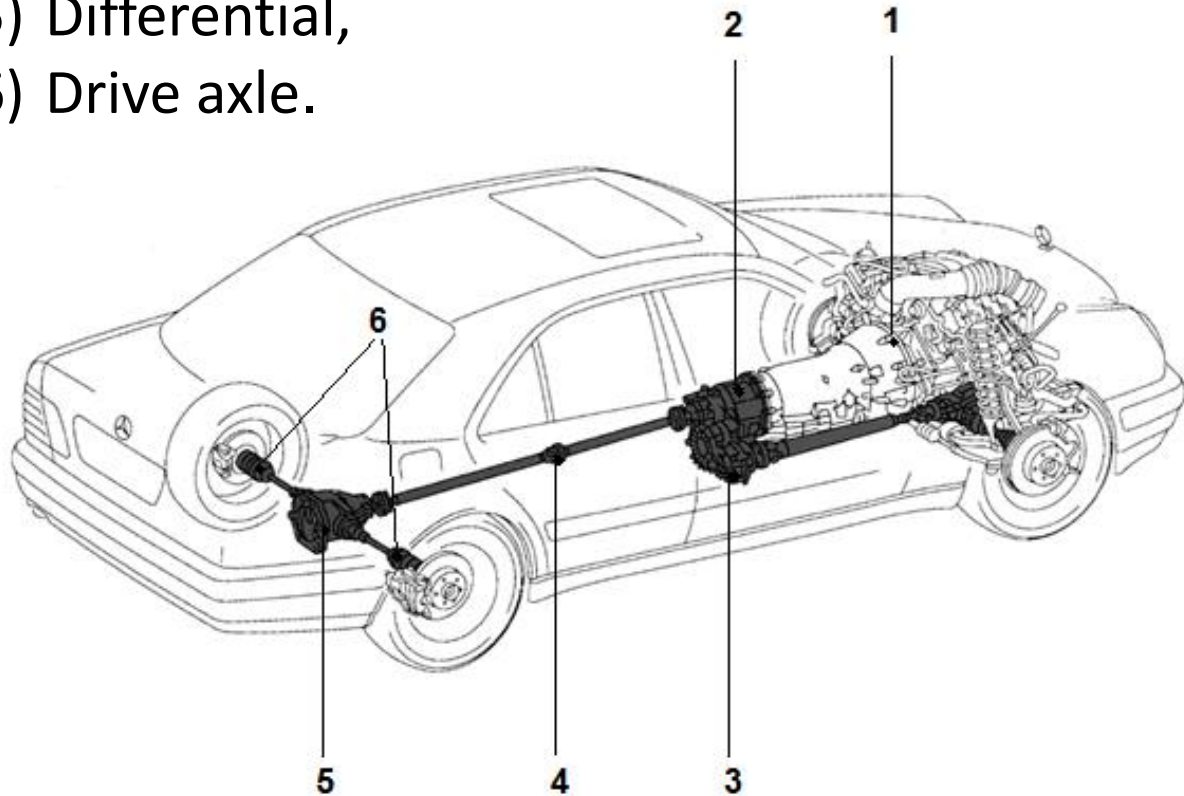

# Powertrain

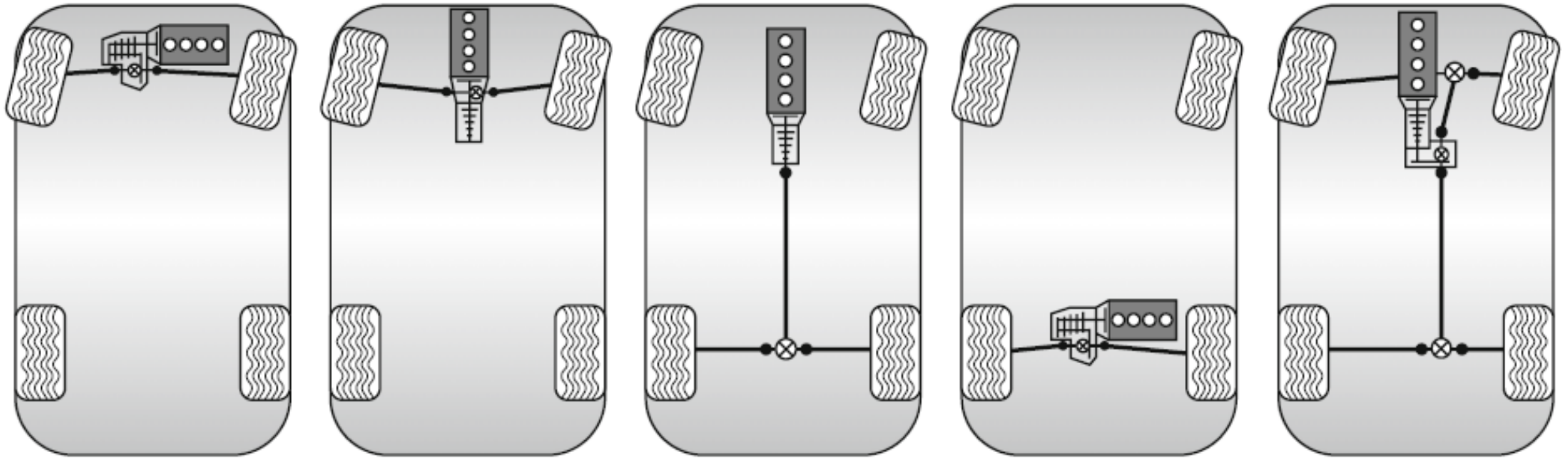

CROLLA, D. 2009. *Automotive Engineering e-Mega Reference*, Elsevier Science.

The actual torque delivered to the drivetrain is reduced by the amount required to accelerate the inertia of the rotating components.

The total ratio of the powertrain

$$i_A = i_S i_G i_E .$$

The ratio of output speed  $n_2$  to input speed  $n_1$  of a powertrain component is defined as **speed conversion**

$$v = \frac{n_2}{n_1} .$$

The torque conversion  $\mu$

$$\mu = \frac{T_2}{T_1} .$$

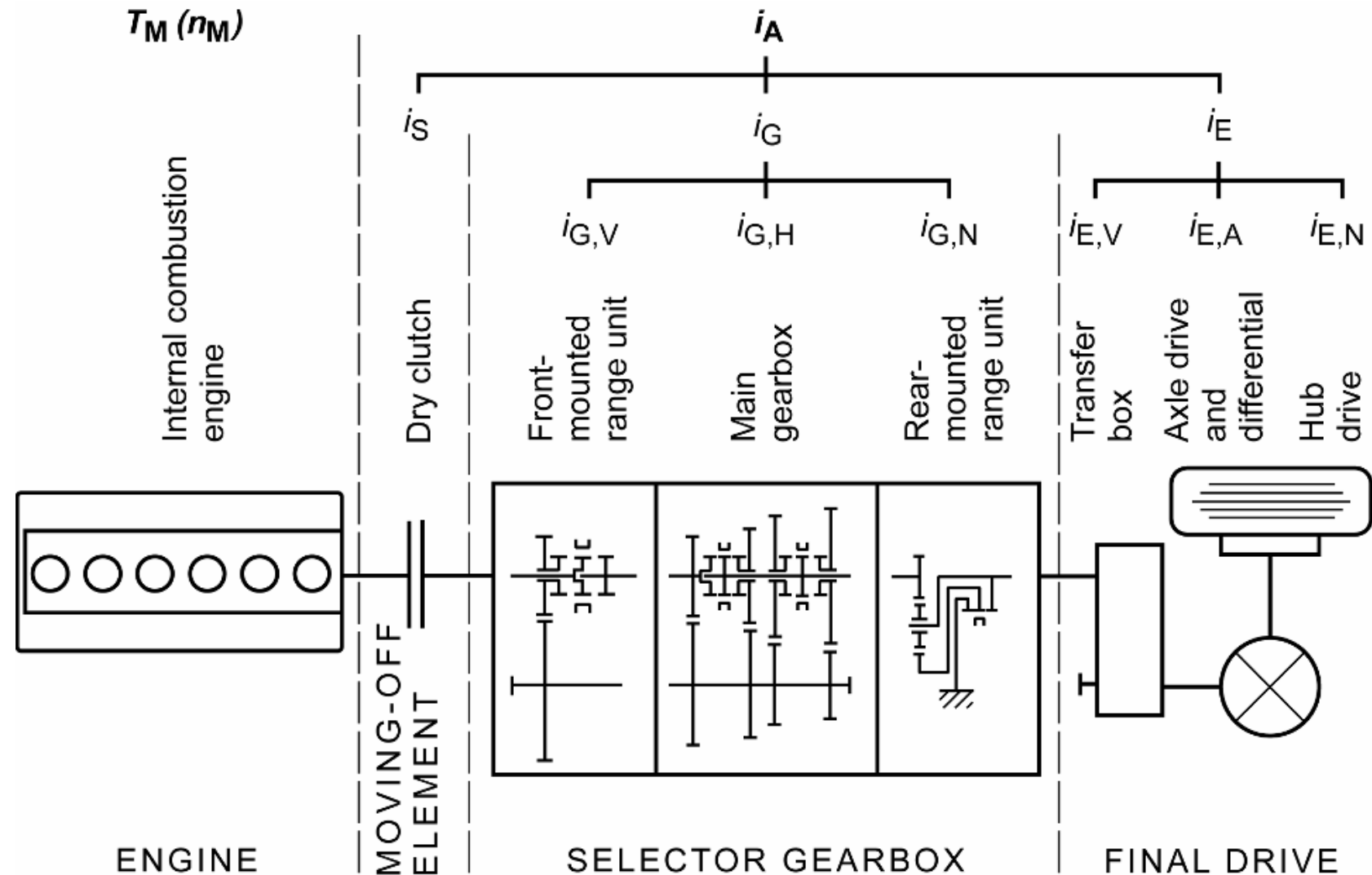

# Transmission

## *Gear box*

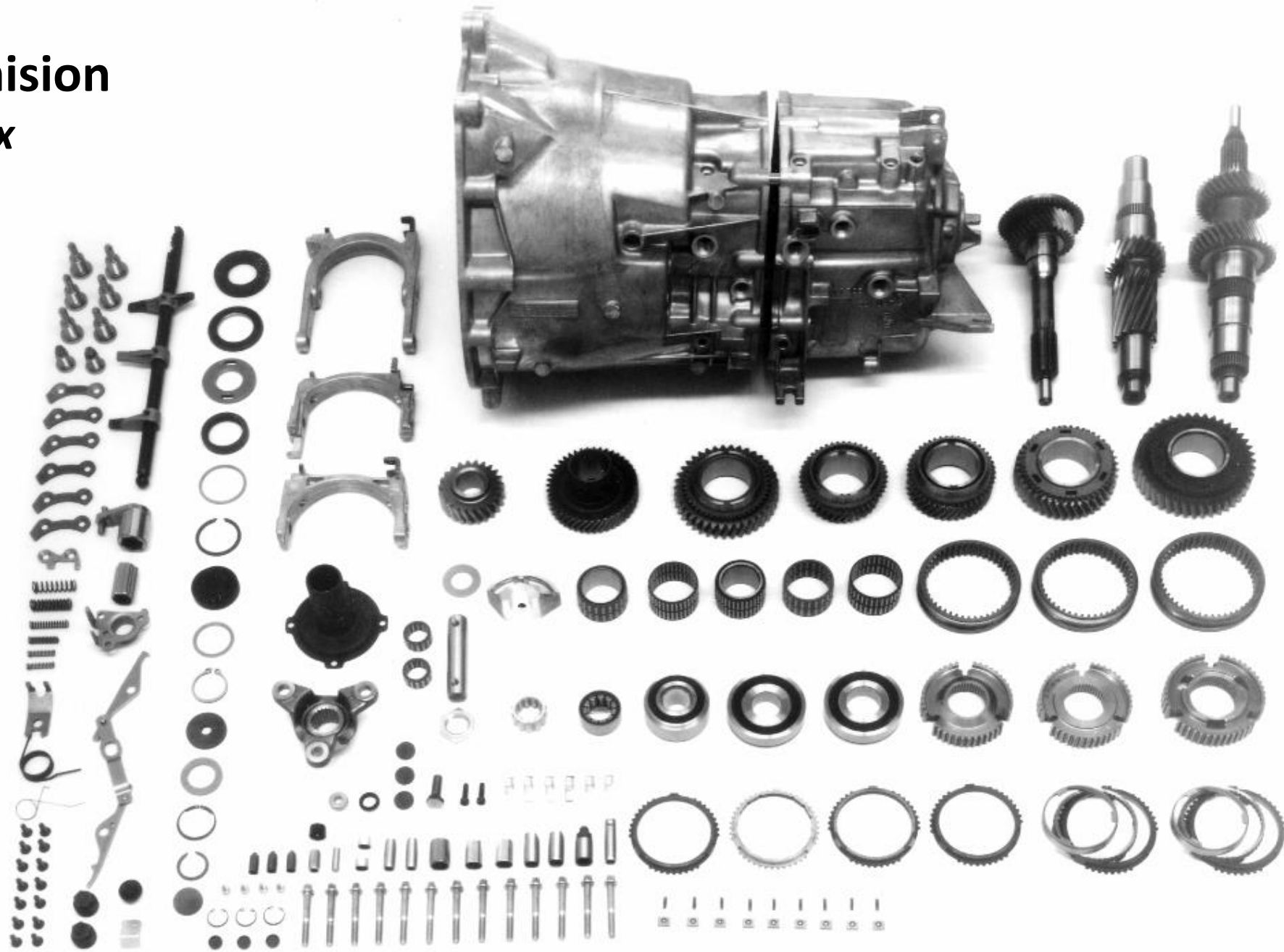

# Gear ratios

- move-off under difficult conditions,  $i_{A,max}$
- reach the required maximum speed  $i_{A(v_{max,th})}$ .
- operate in the fuel-efficient ranges of the engine performance map  $i_{A,min}$ .

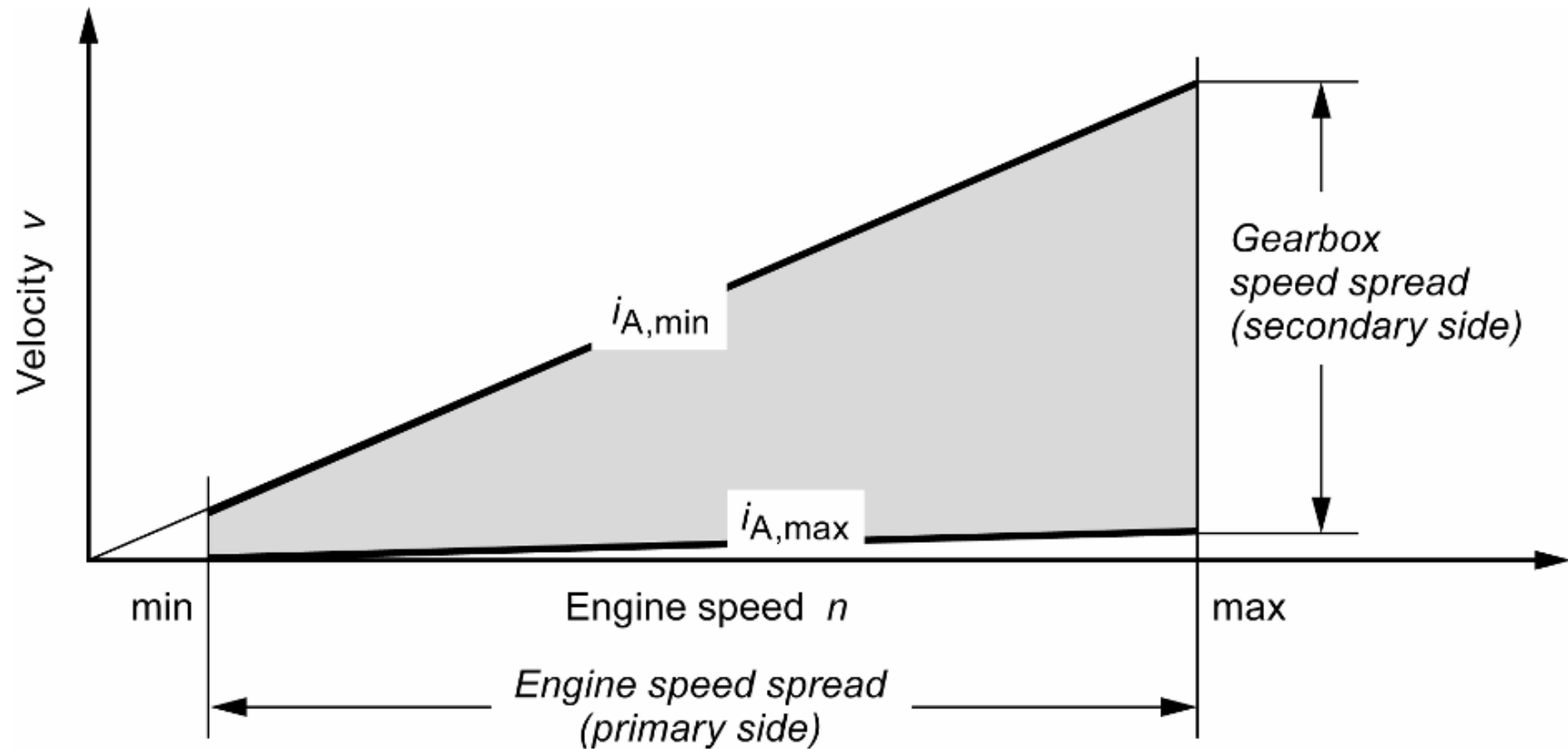

# Overall Gear Ratio

$$i_{G,\text{tot}} = \frac{i_{G,\text{max}}}{i_{G,\text{min}}} = \frac{i_1}{i_z}, \quad \text{with the gears } n = 1 \text{ to } z.$$

## The overall gear ratio depends on:

- the specific power output of the vehicle
  - the engine speed spread
  - the intended use.
- *Vehicles with a low specific power output, such as commercial vehicles, need a larger overall gear ratio.*
    - *The same applies for vehicles with diesel engines, which have a small engine speed spread.*



# The Largest Powertrain Ratio $i_{A,\max}$

- The greatest traction requirement must be known to determine the ratio of the gear with the largest torque multiplication.
- **The friction limit** – i.e. the maximum force that can be transmitted between the tyres and the road – is a physical limit and must be taken into account when establishing the traction  $F_{Z,A}$  at the road wheels

$$F_{Z,A} \leq F_{Z,\max} = \mu_H R .$$

- At the drive wheels a balance must be struck between the maximum requirements of **acceleration, gradient, road surface, payload and trailer load:**

*Maximum traction available  $F_{Z,A} = \text{Maximum traction required } F_{Z,B}$*

$$T_{M,\max} i_{A,\max} \eta_{\text{tot}} \frac{1}{r_{\text{dyn}}} = m_F g (f_R \cos \alpha_{\text{St}} + \sin \alpha_{\text{St}}) + m_F \lambda a .$$

# The Largest Powertrain Ratio $i_{A,\max}$

## *Climbing performance*

- The maximum gradient that can be climbed at an acceleration of  $a = 0$  m/ss
- This ensures that a trailer can be towed and steep ramps overcome with ease.

$$i_{A,\max} = \frac{r_{\text{dyn}} m_F g (f_R \cos \alpha_{\text{St}} + \sin \alpha_{\text{St}})}{T_{M,\max} \eta_{\text{tot}}}$$

## *Acceleration performance*

- The maximum acceleration on the level.
- Acceleration performance depends not only on the stall torque ratio, but also to a significant degree on how closely the gears approximate to the traction hyperbola.

$$T_{M,\max} i_{A,\max} \eta_{\text{tot}} \frac{1}{r_{\text{dyn}}} = m_F g (f_R \cos \alpha_{\text{St}} + \sin \alpha_{\text{St}}) + m_F \lambda a .$$

$$a_{\max} = \frac{F_{Z,\text{Ex}}}{m_F \lambda_{\text{n}}}$$

# Commercial vehicles

*(building site vehicles)*

- The largest ratio in **commercial vehicles** is often dictated by the vehicle's intended use.
- building site vehicles and road sweepers have gears for extremely slow movement

$$i_{A,\max} = \frac{3.6 \frac{\pi}{30} n_{M,\min} r_{\text{dyn}}}{v_{\text{crawl}}}$$

*These very high-ratio gears are known as **crawler gears**.*

# The Smallest Powertrain Ratio $i_{A,\min}$

$$i_{A,\min} = \frac{3.6 \frac{\pi}{30} n_{M,\max} r_{\text{dyn}}}{v_{\max}}$$

Assuming there is no slip in the power transmission from wheel to road and that the (desired) maximum speed is reached at maximum engine speed,

*The limiting factors of legal speed restrictions and diesel engine cut-off speed mean that the maximum speed will often be a design parameter when developing **commercial vehicle powertrains**.*

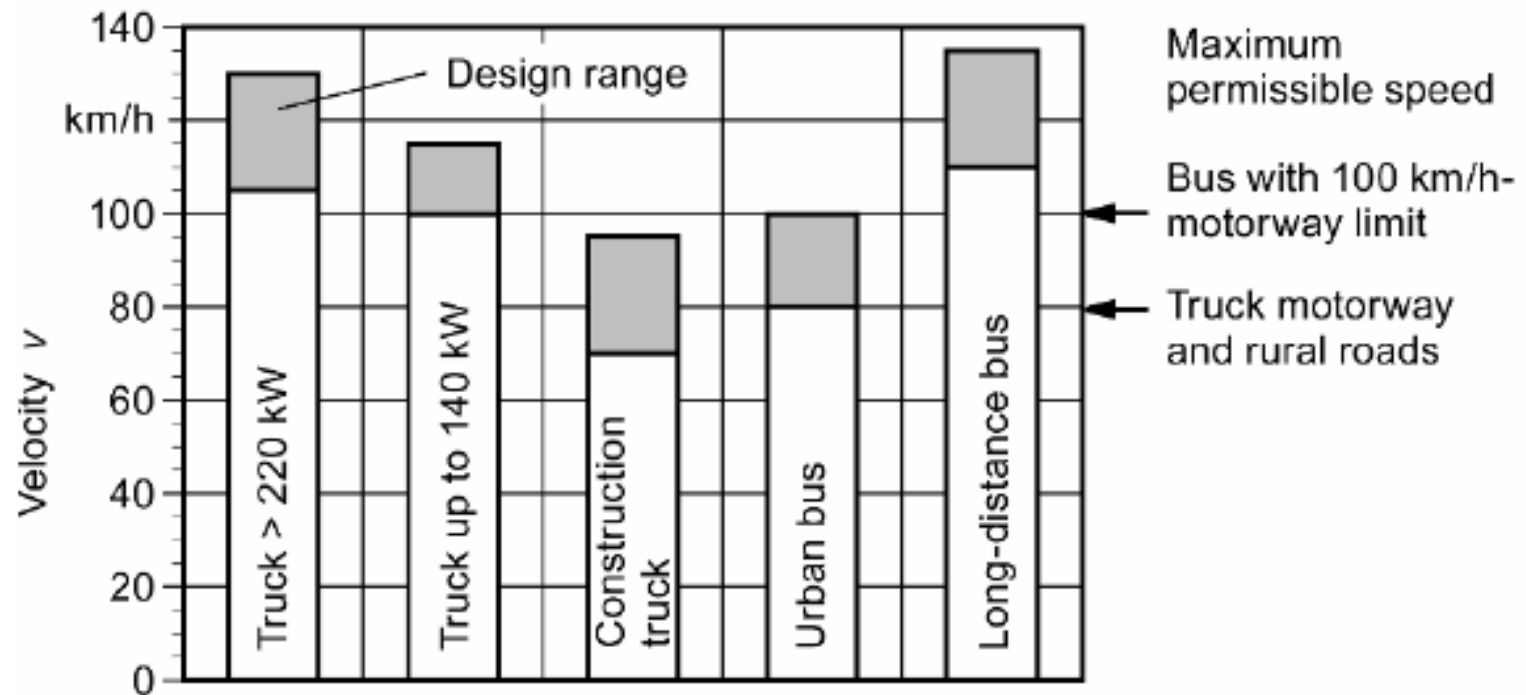

# The Smallest Powertrain Ratio $i_{A,min}$

Passenger cars

## 1/ $v_{max}$ – Optimum Design

The excess power available  $P_{Z,Ex}$  is a measure of acceleration reserve, and the engine speed  $n_M$  serves as a measure for fuel consumption

## Overrevving Design

The high level of excess power  $P_{Z,Ex2}$  makes this arrangement preferable for sports designs

## Underrevving Design

The reduction in engine speed is the important feature of this design. The operating point moves into an area of improved fuel consumption.

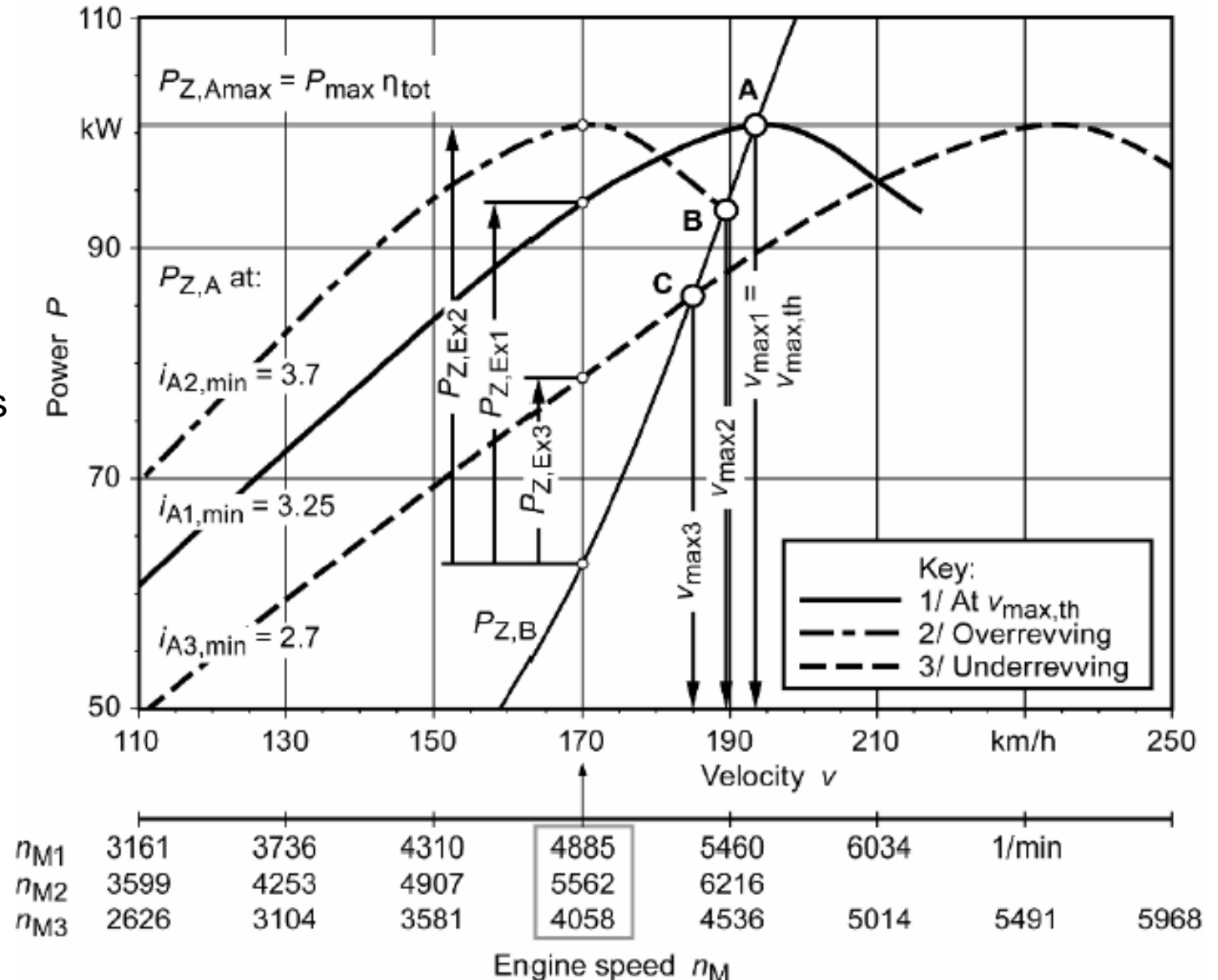

# underrevving powertrain ratios to improve fuel economy

a powertrain optimised for  $v_{\max,th}$

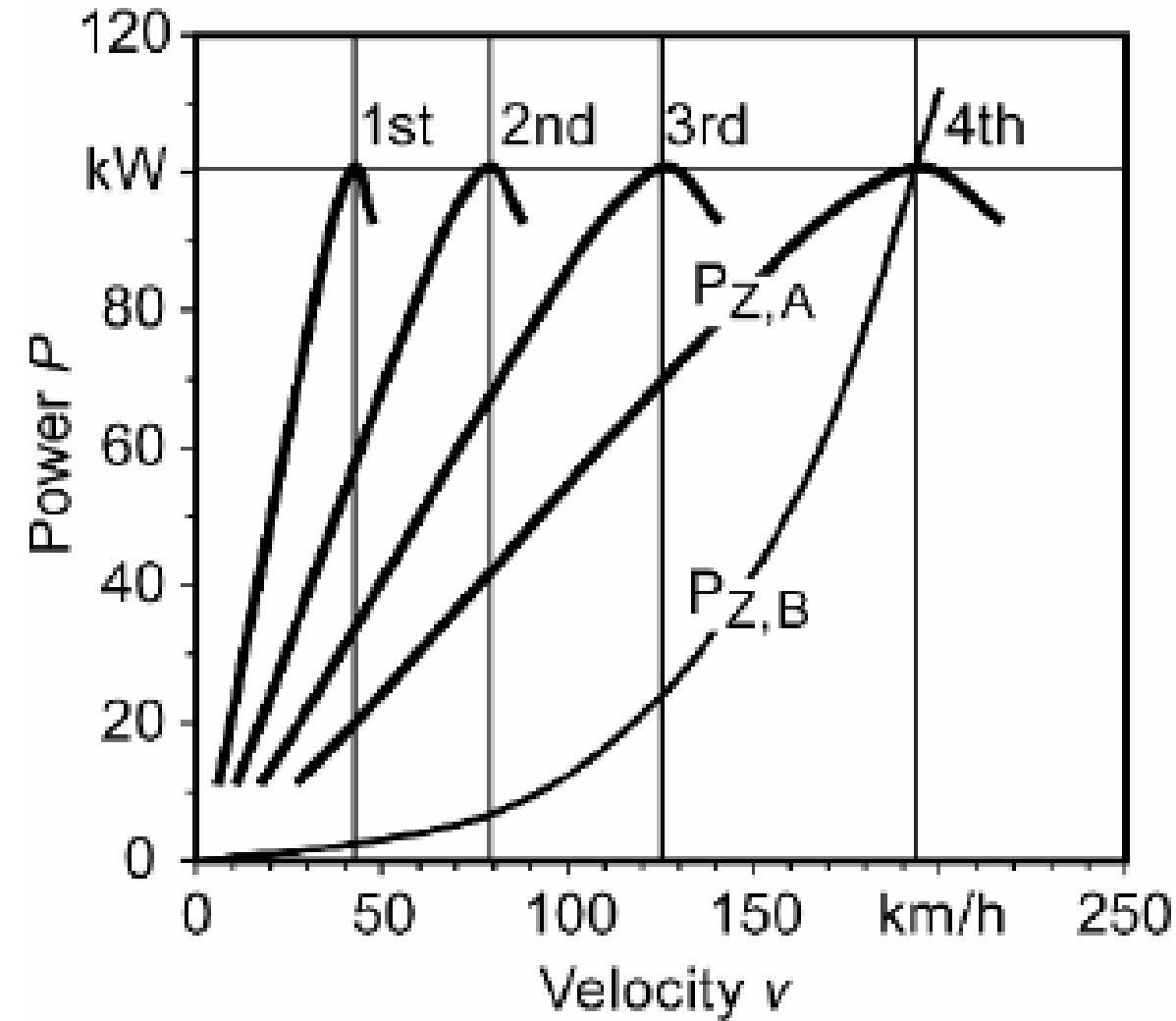

# increase the overall gear ratio with the same number of speeds

The effect of increasing the overall gear ratio with the same number of gears is to **create relatively large gaps in the power output**, thus reducing the vehicle's acceleration performance.

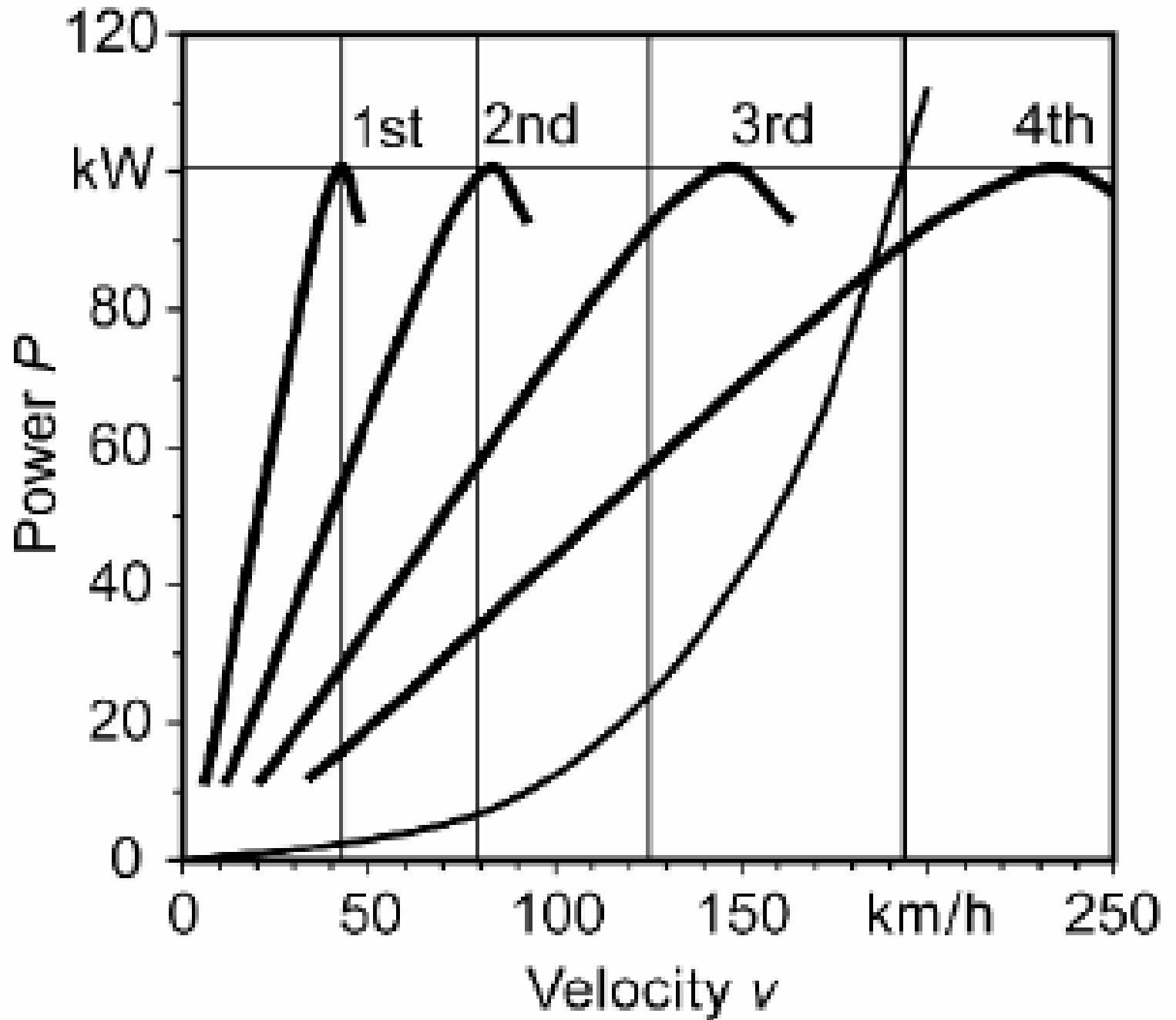

## reduce the final ratio ("long axle design")

Increasing the final ratio ("long axle design") with the same overall gear ratio leads to a smaller stall torque ratio, and thus to reduced climbing performance and increased clutch stress when moving-off.

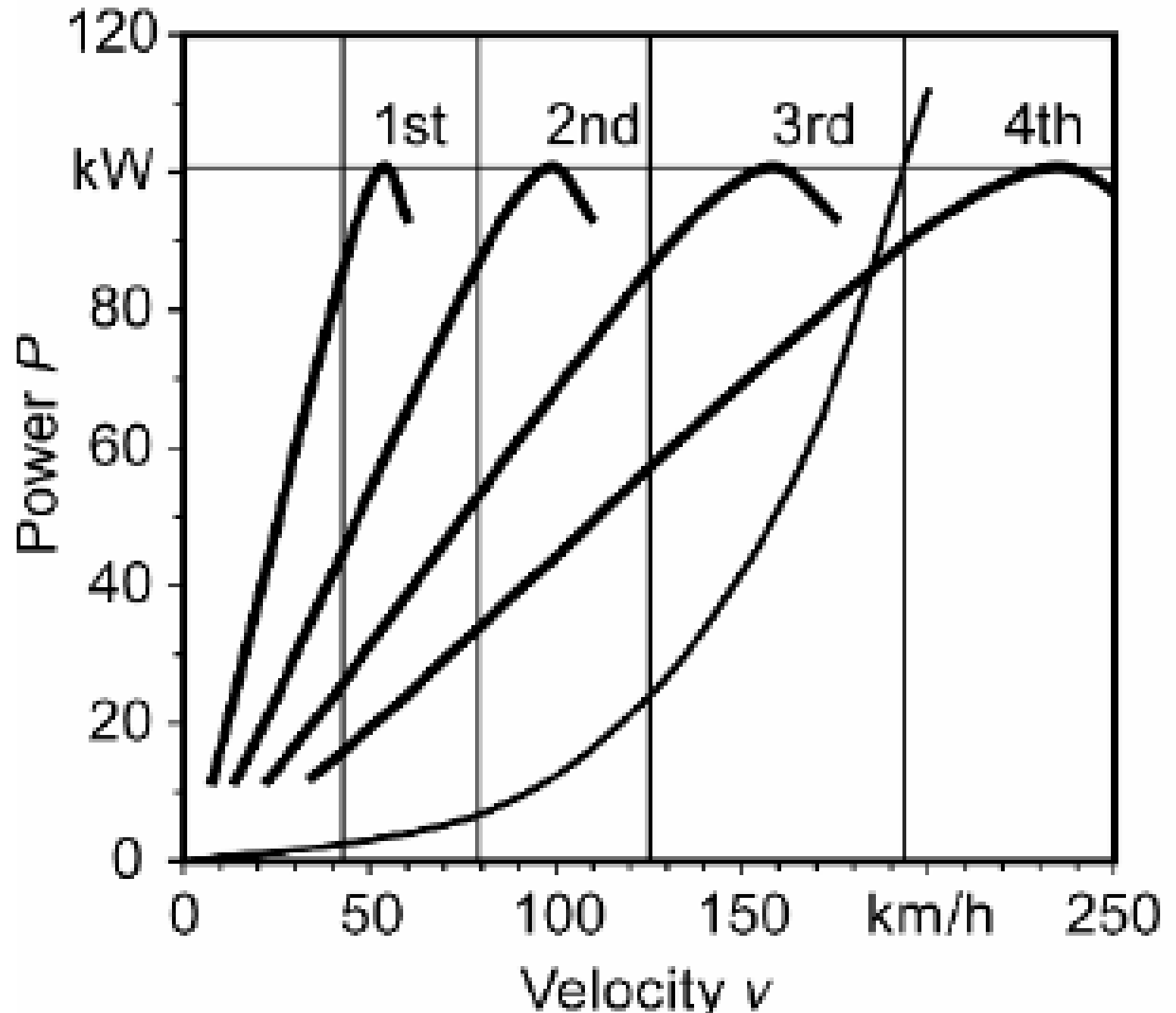



increase the overall gear ratio by increasing the number of gears – overdrive –

The fifth and sixth speed on manual passenger car gearboxes can be designed as overdrives to reduce engine speed

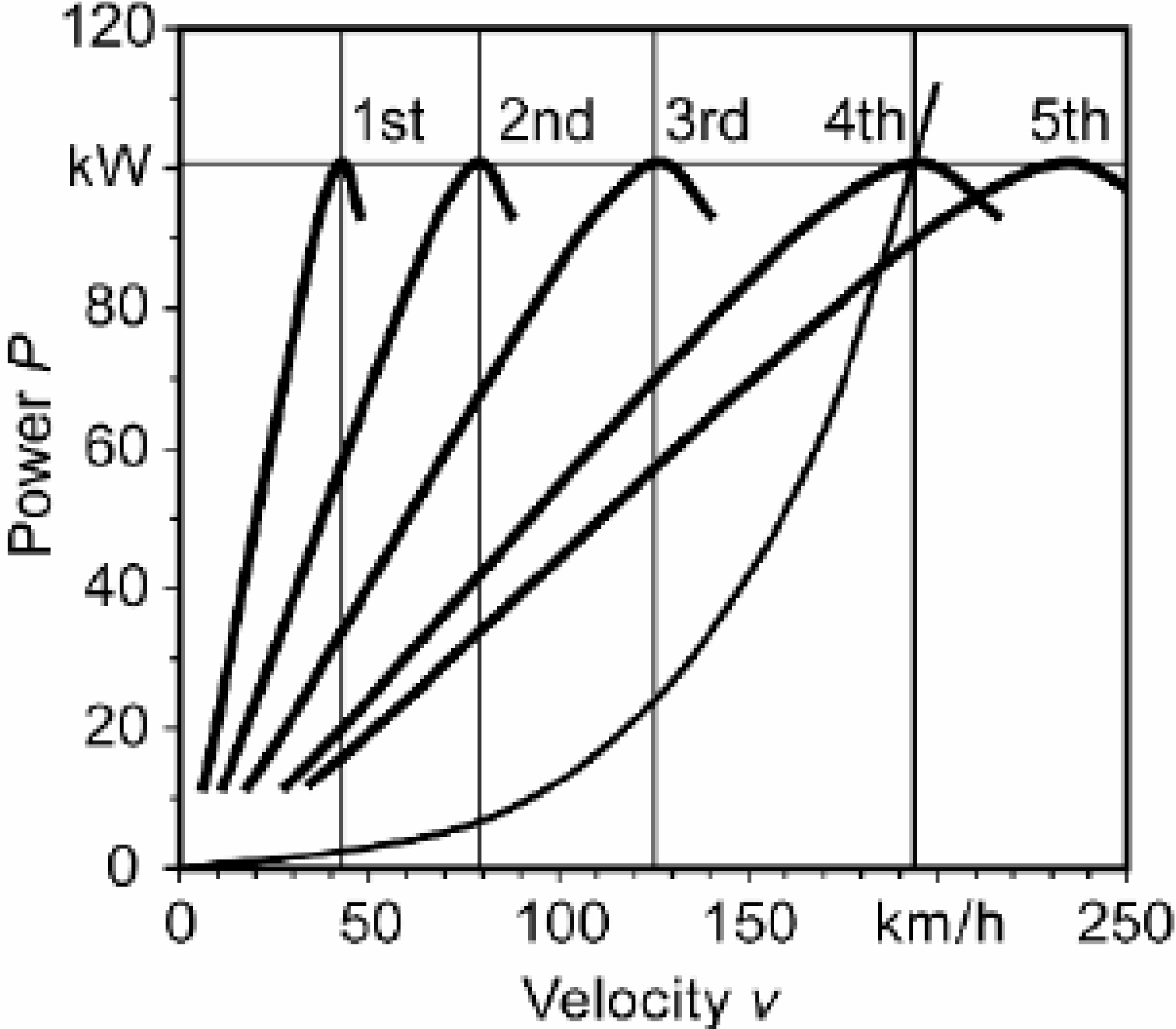

# Selecting the Intermediate Gears

The relationship between the ratios of two neighbouring gears, the gear step  $\varphi$ , is given by

$$\varphi = \frac{i_{n-1}}{i_n} \leq \frac{n_{\max}}{n(T_{\max})}$$

- The greater the number of gears, the better the engine exploits its efficiency by adhering to the traction hyperbola. *But as the number of gears increases, so does the frequency of gearshifting and the weight and size of the gearbox.*
- The proportion of distance travelled in the lower gears is low, especially in the case of passenger cars.
- The proportion of distance travelled in each gear depends on the specific power output (kW/t), the traffic conditions and driver behavior
- The smaller the gear step  $\phi$ , the easier and more pleasant the gearshift action
- **The thermal load on the synchronizer rings is proportional to the square of the gear step.**

# The velocity/engine-speed diagram

The saw profile diagram shows the earliest upshift possible without stalling the engine and the earliest downshift possible without exceeding the maximum engine speed

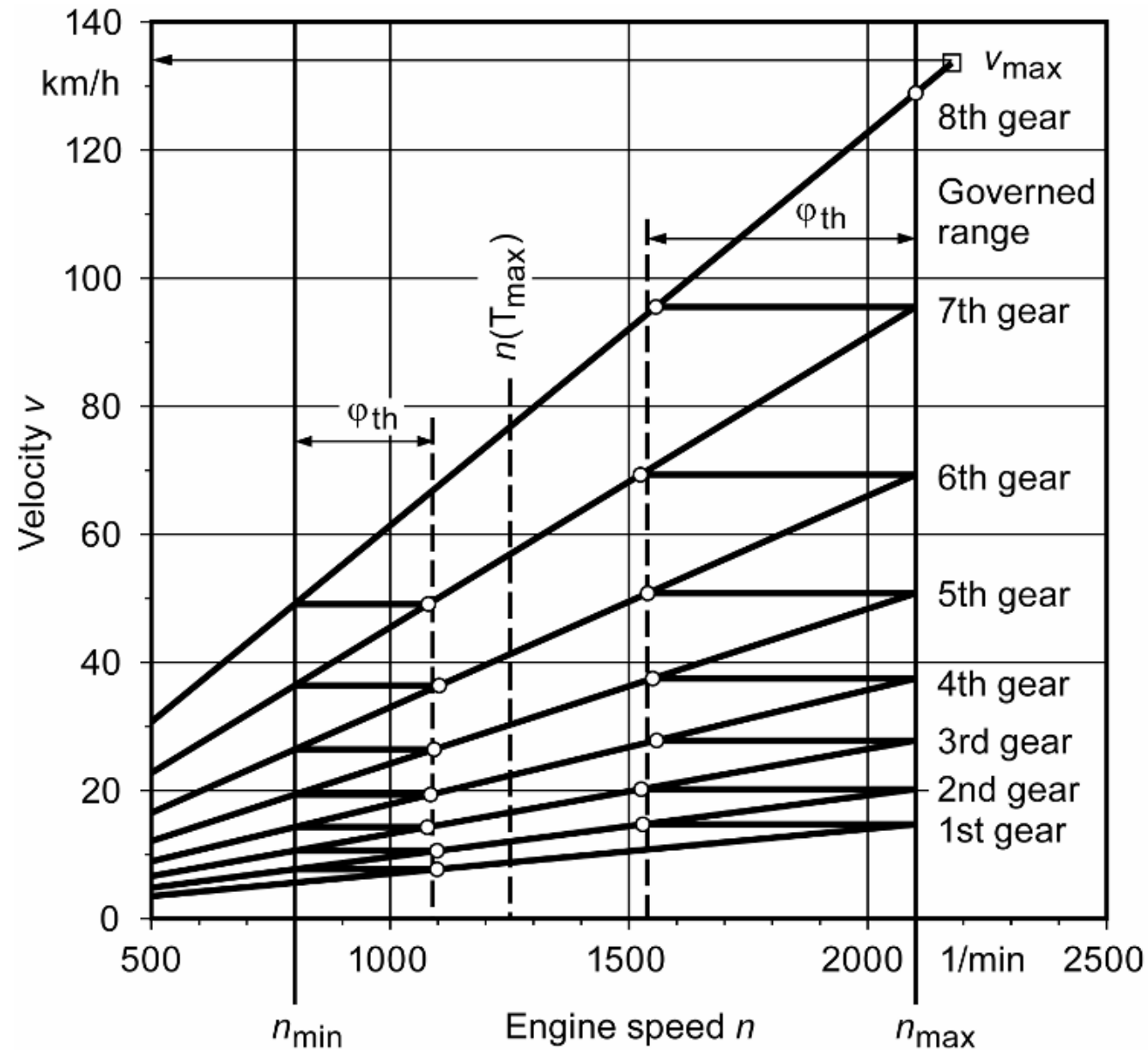

Ratios:	$\phi$ :
$i_1$ : 8.73	1.37
$i_2$ : 6.38	1.38
$i_3$ : 4.63	1.35
$i_4$ : 3.44	1.35
$i_5$ : 2.54	1.37
$i_6$ : 1.86	1.38
$i_7$ : 1.35	1.38
$i_8$ : 1.0	1.35

# Methods for calculating gear steps

## *geometrical gear steps* (commercial vehicle)

- In the geometric design the gear step  $\varphi$  between the individual gears always has the same theoretical value
- The lower specific power output means all the gear steps are of equal significance

$$\varphi_{th} = z^{-1} \sqrt{i_{G,tot}}$$

The ratios of the individual gears  $n = 1$  to  $z$  is then given by

$$i_n = i_z \varphi_{th}^{(z-n)}$$

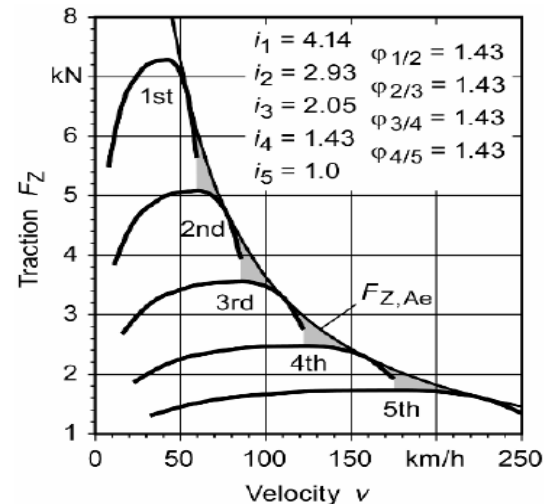
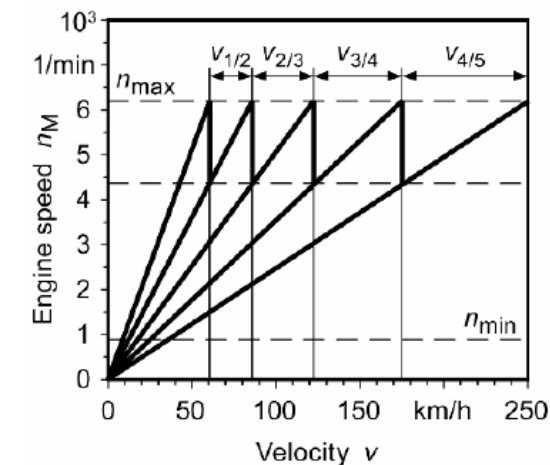

## *progressive gear steps* Passenger vehicle

In the traction diagram the gaps between the effective traction hyperbola and the traction available are reduced in the top gears (*improved shifting comfort (smaller  $\varphi$ ), and in improved acceleration performance*)

Given the overall gear ratio  $i_{G,tot}$  and the selected **progression factor  $\varphi_2$** , the base **ratio change  $\varphi_1$**  can be calculated

$$\varphi_1 = z^{-1} \sqrt{\frac{1}{\varphi_2^{0.5(z-1)(z-2)}} i_{G,tot}}$$

$$i_n = i_z \varphi_1^{(z-n)} \varphi_2^{0.5(z-n)(z-n-1)}$$

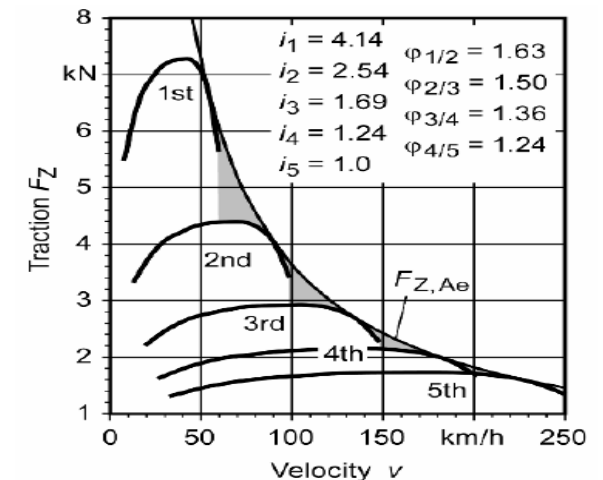
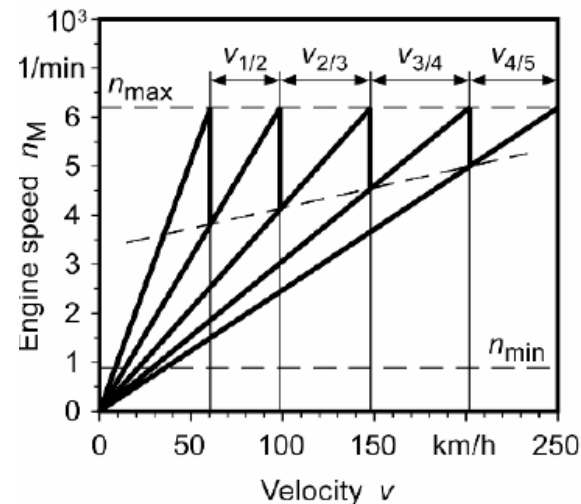

# Gear ratios

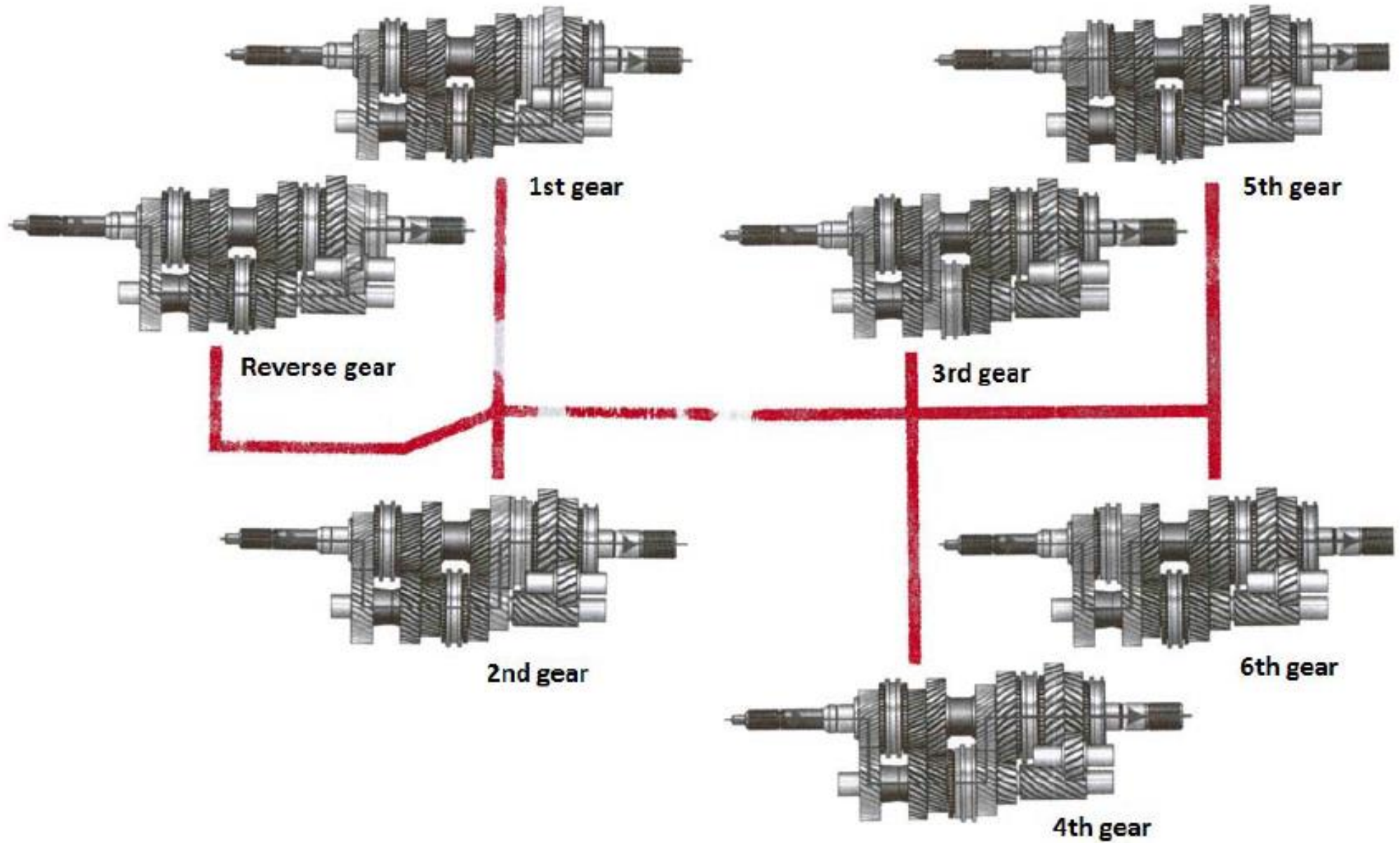

# Gearshifting

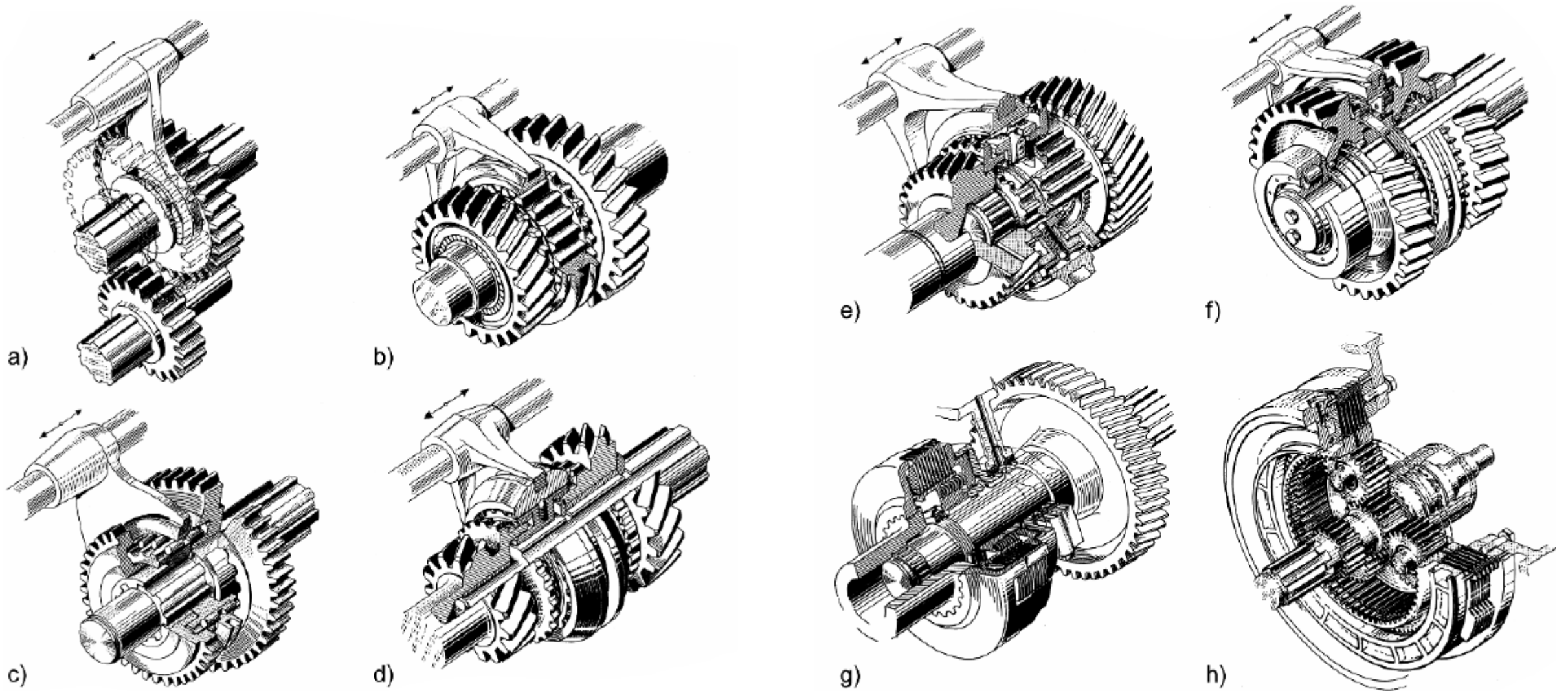

## Internal shifting elements in automotive transmissions.

**a** Sliding gear; **b** dog clutch engagement; **c** pin engagement; **d** synchronizer without locking mechanism; **e** synchronizer with locking mechanism; **f** servo lock synchronizer mechanism (Porsche system); **g** hydraulically activated multi-plate clutch for powershift transmission; **h** hydraulically activated multi-plate brake for planetary gear

# Cross section of a front-wheel-drive manual gearbox

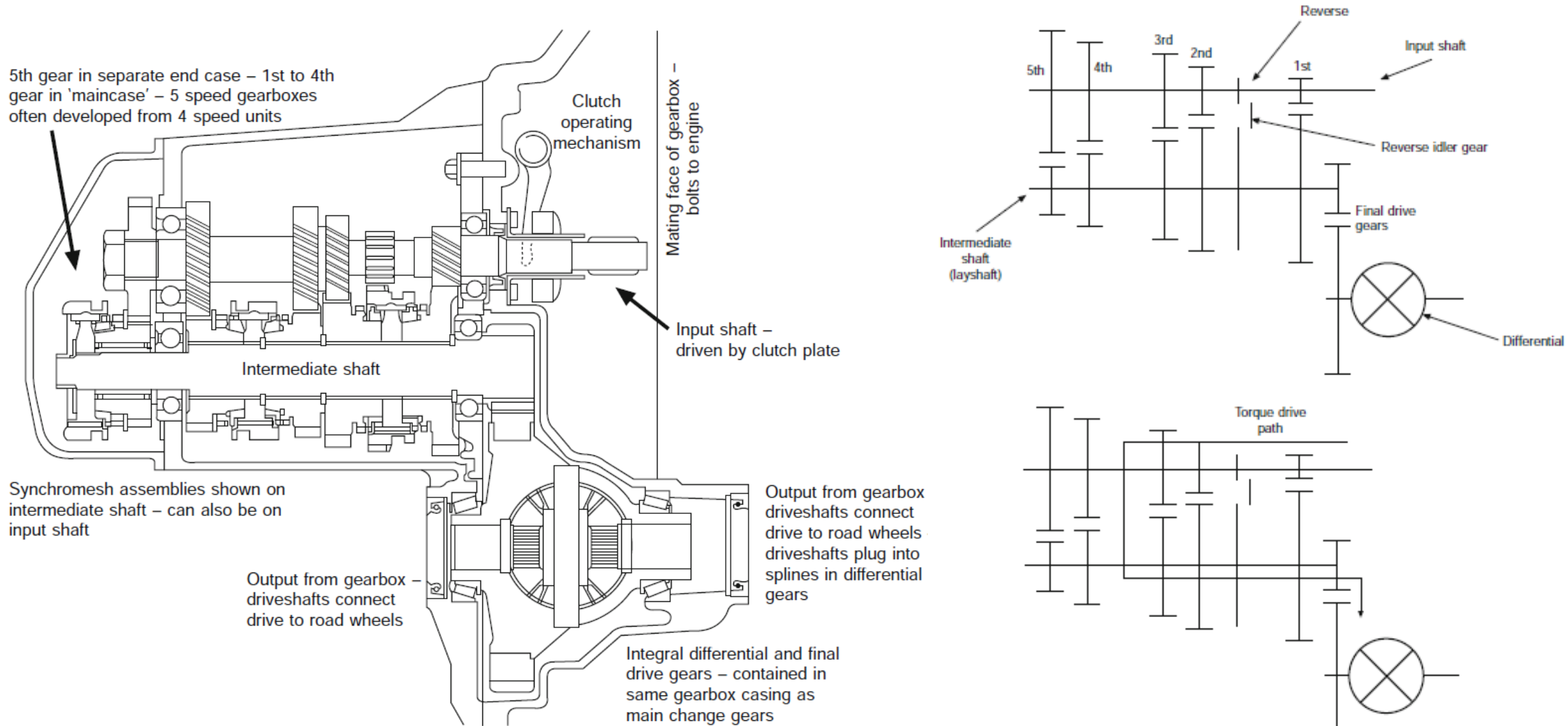

# Cross section of a rear-wheel-drive manual gearbox

Typical design features of a rear-wheel-drive car gearbox:

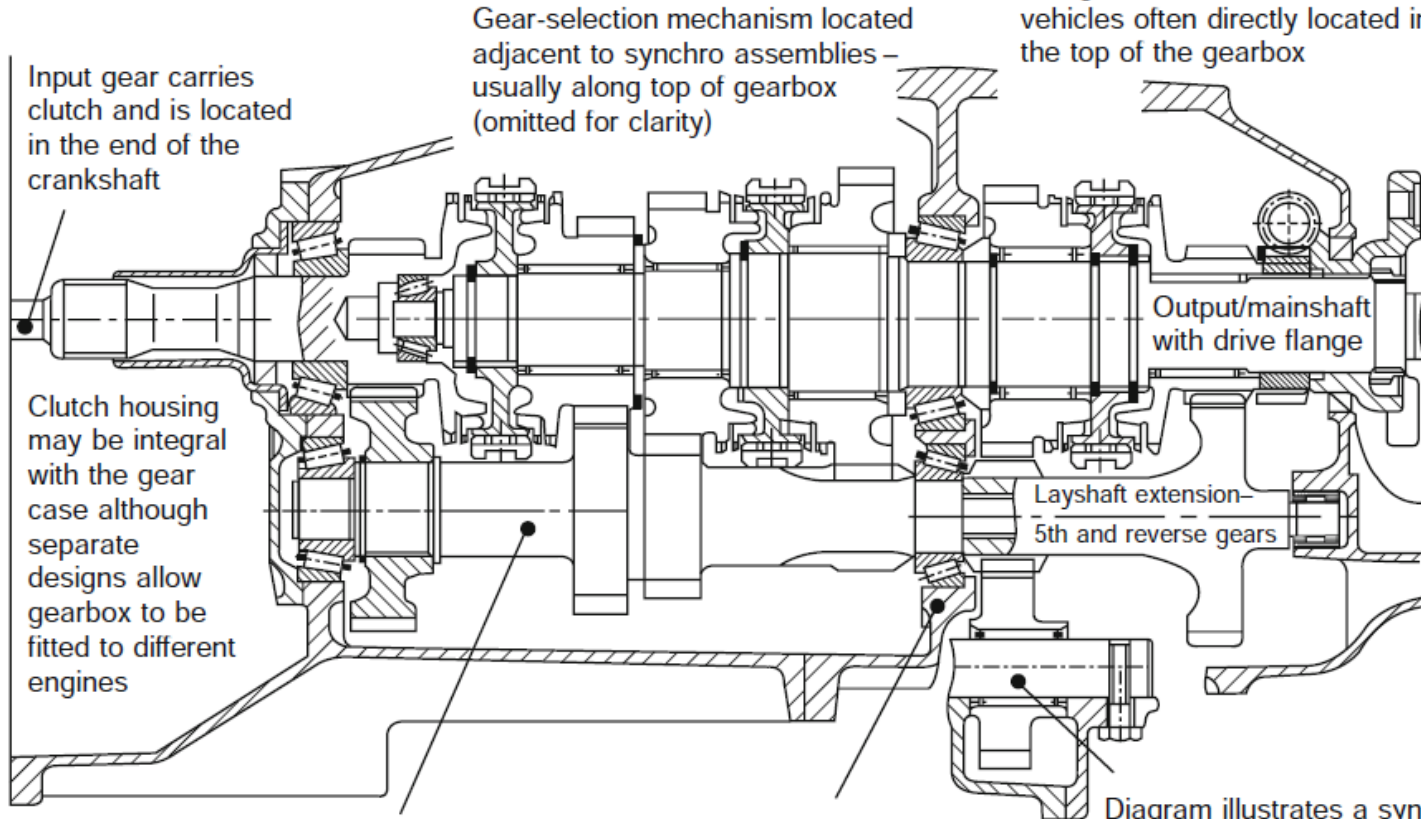

Input gear carries clutch and is located in the end of the crankshaft

Gear-selection mechanism located adjacent to synchro assemblies – usually along top of gearbox (omitted for clarity)

External gear-selection mechanism (i.e. gear lever) on rear wheel drive vehicles often directly located into the top of the gearbox

Output/mainshaft with drive flange

Layshaft extension – 5th and reverse gears

Clutch housing may be integral with the gear case although separate designs allow gearbox to be fitted to different engines

Layshaft may be solid construction or an assembly of several parts

Gearcases often have centre bearing support plate although other designs have shafts supported only at the ends

Diagram illustrates a synchronized reverse gear – may also be engaged by the idler gear sliding in/out of mesh (Reverse idler gear shown out of position – engages with mainshaft)

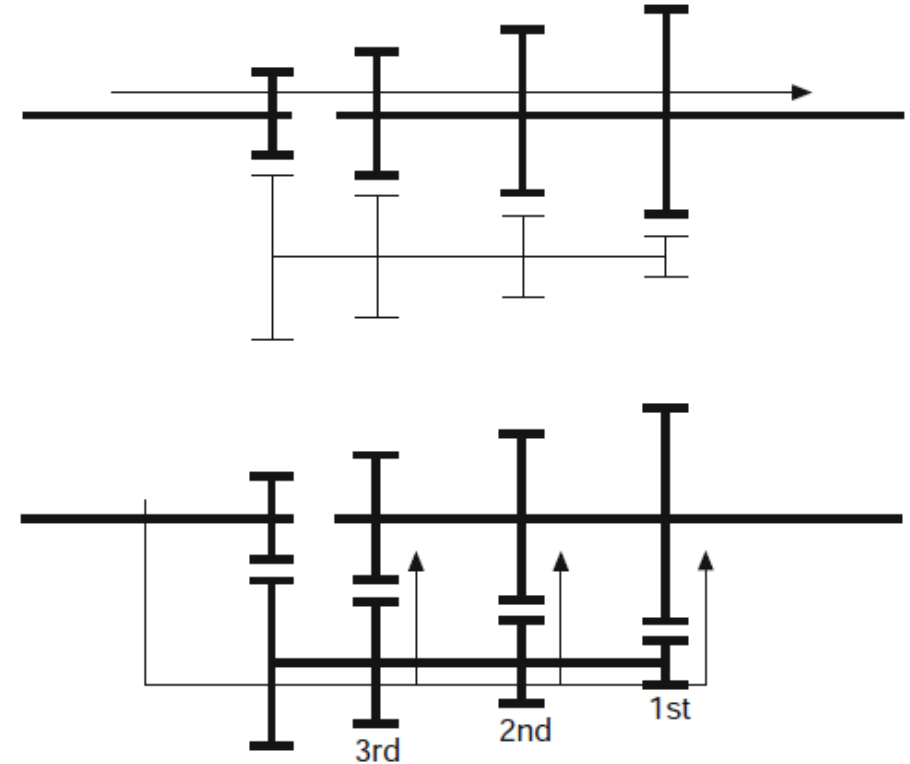



# Gearchanging and the synchromesh

- The work done by the synchromesh assembly is to change the speed of the inertia on the layshaft and input shaft, which includes the clutch driven plate.
- Synchromesh is effectively a cone brake device, and the action of the driver in applying force to the sleeve allows the two sides of the assembly to tend towards the same speed.
- In the first part of the synchronizing process, the sleeve applies a load onto the baulk ring, which is rotating at a different speed to the cone onto which it is pushed.
- The friction that is created by this causes the speed of the two parts to become the same. At this point, the sleeve is able to move past the baulk ring and engage with the gear, and the gearshift is complete

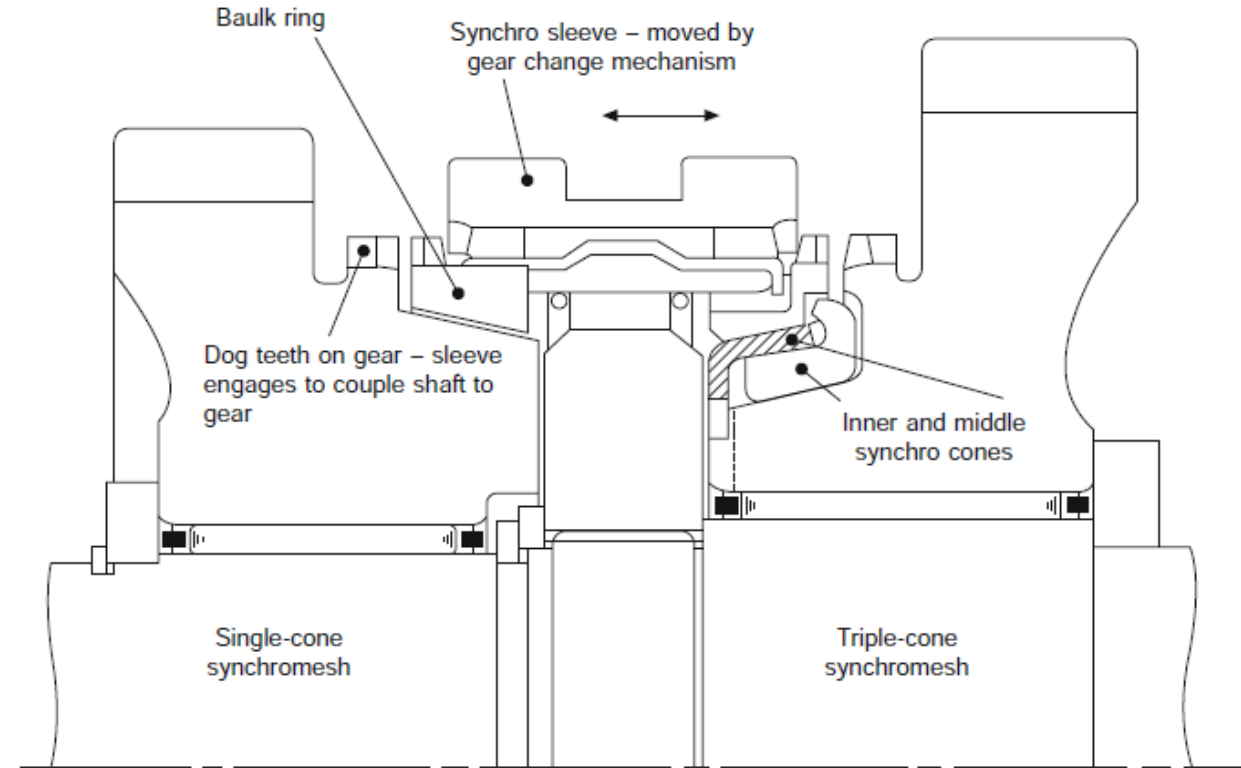

CROLLA, D. 2009. *Automotive Engineering e-Mega Reference*, Elsevier Science.

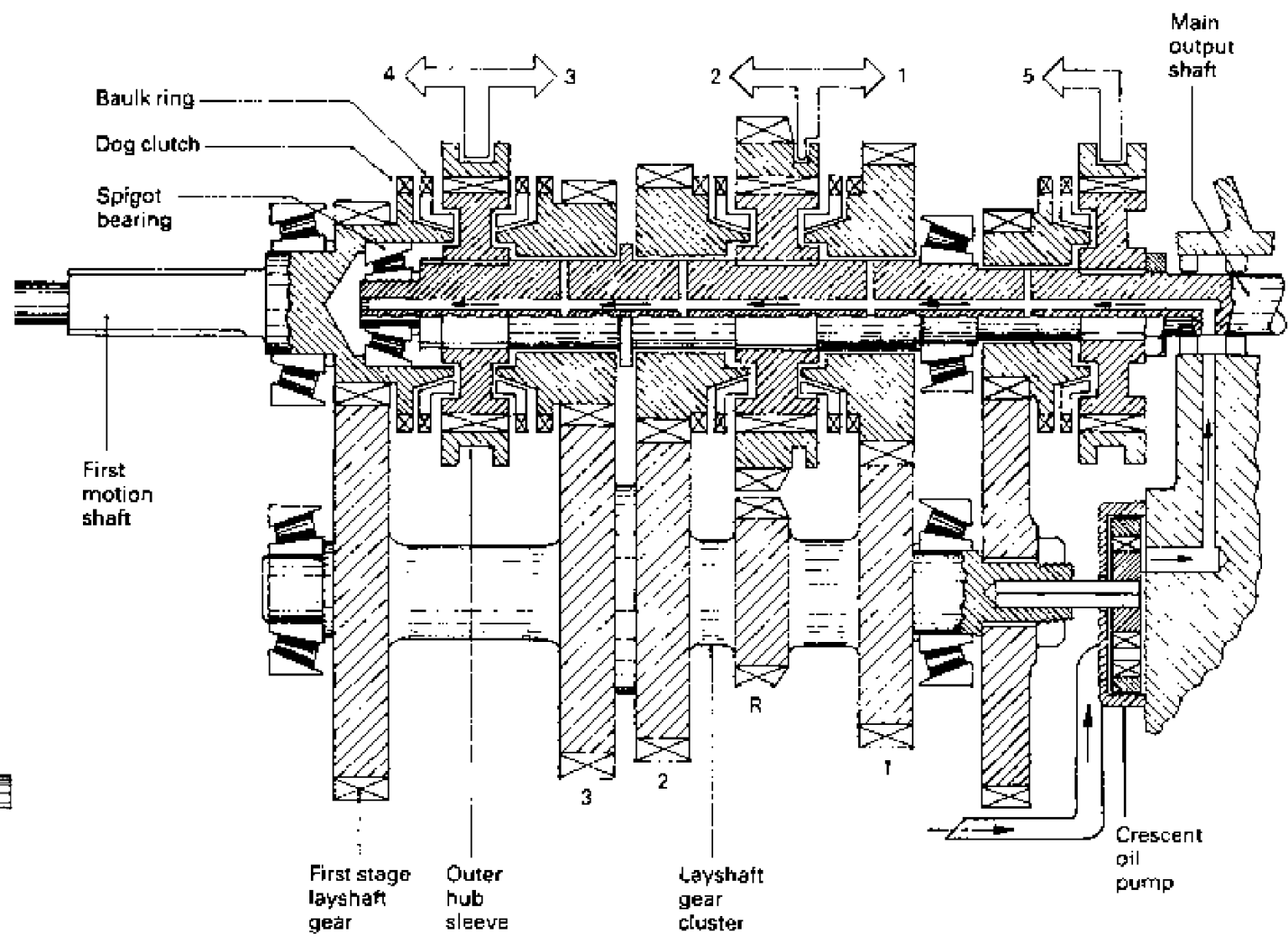
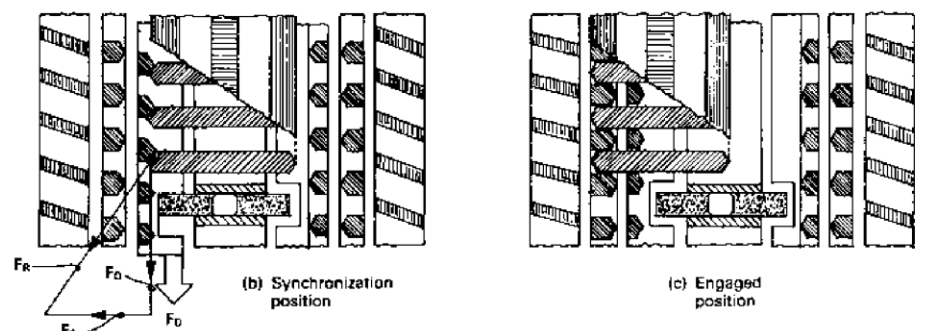
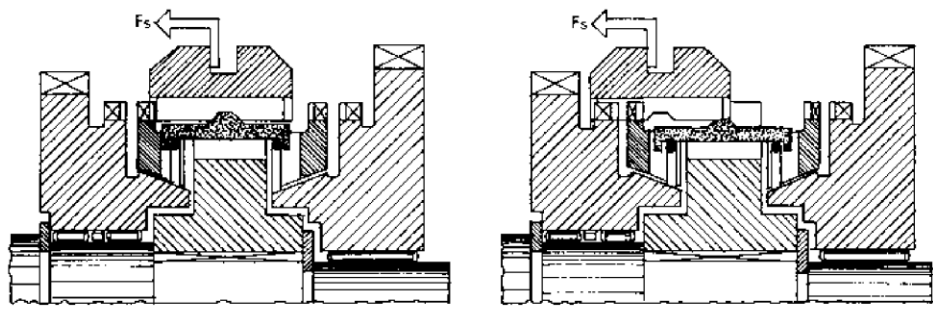
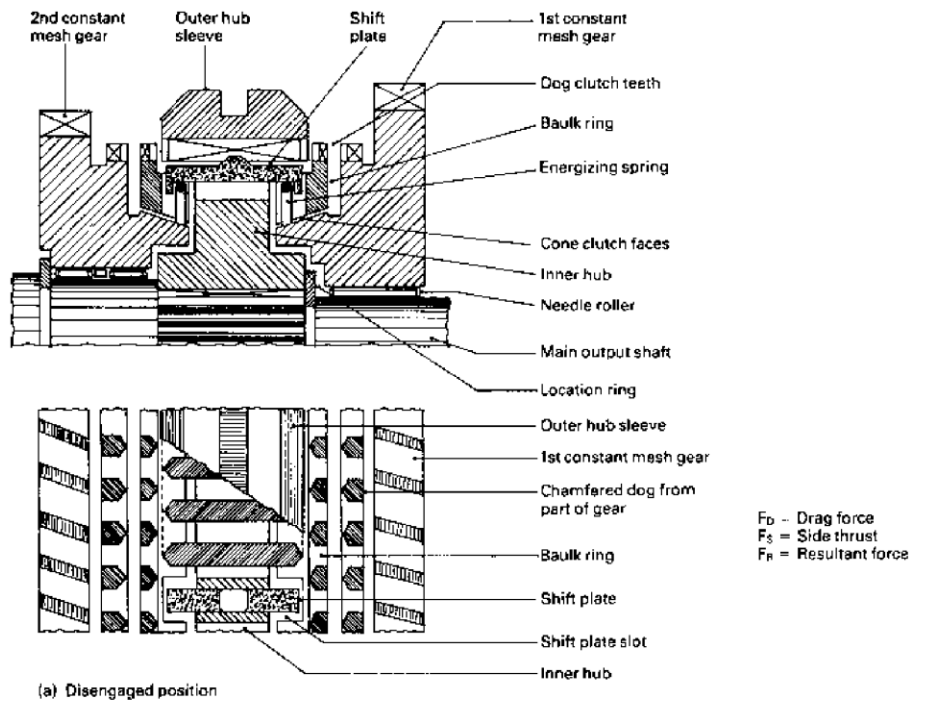

HEISLER, H. 2002. *Advanced Vehicle Technology*, Butterworth-Heinemann.

# Final Drives

The components derived from this classification which fall under the category “final drive” are:

- axle drive,
- differential gear,
- hub drive (commercial vehicles) and
- transfer gearbox (in case of multiple driven axles)

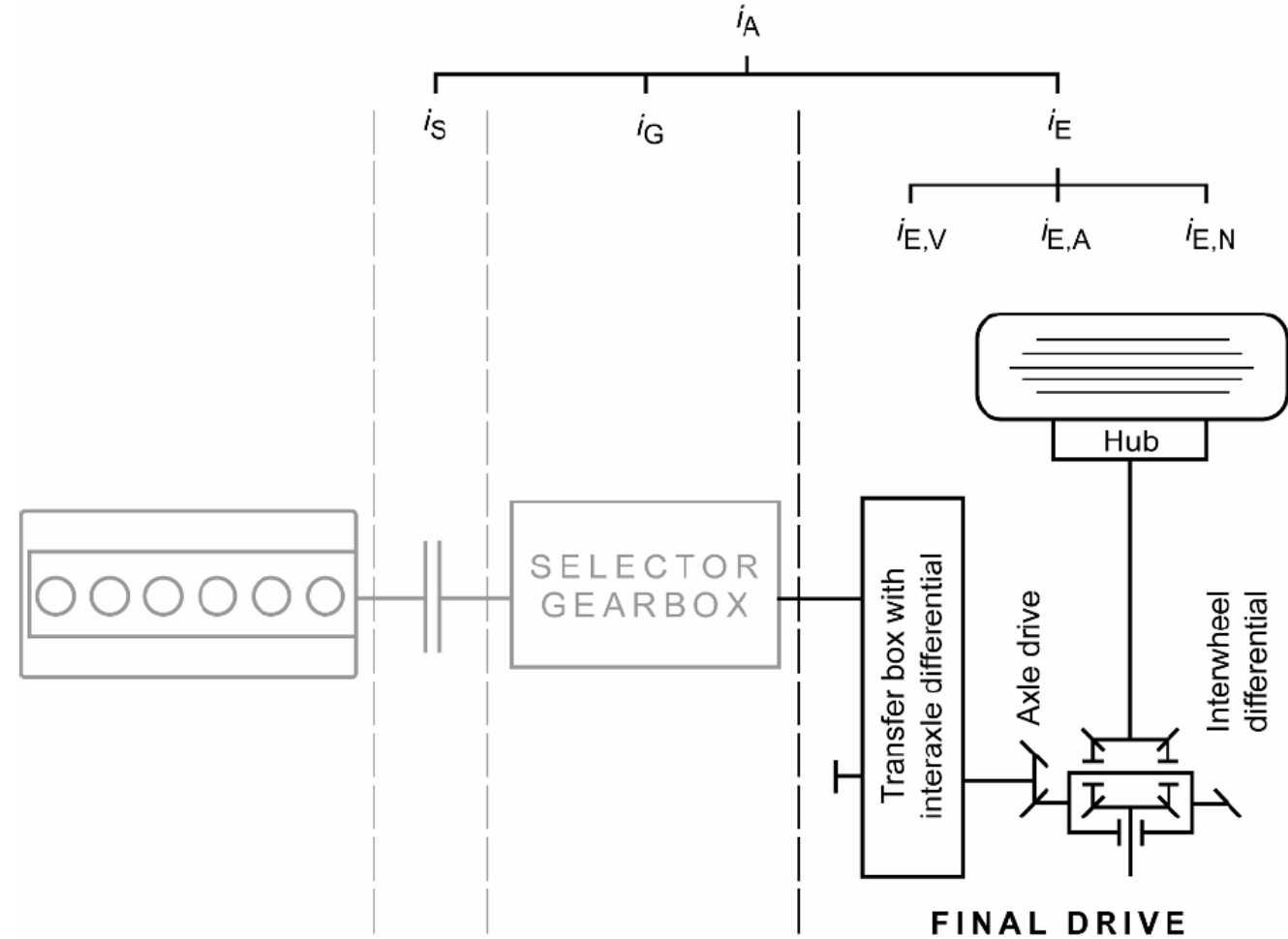

# Final Drives

## *Axle Drives for Passenger Cars*

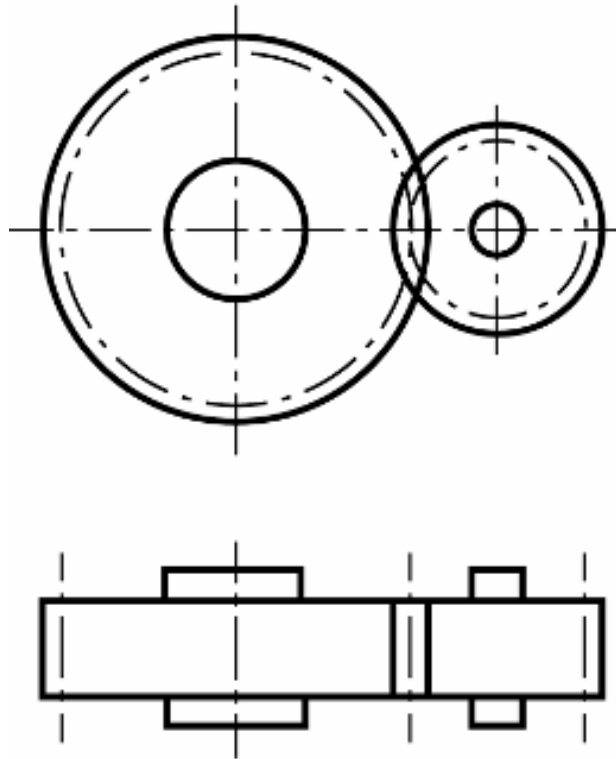

Spur gear axle drive

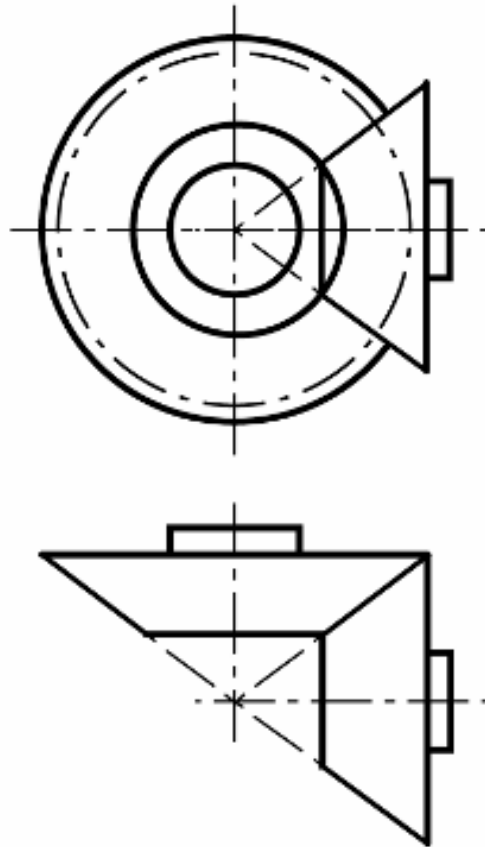

Bevel gear axle drive  
(helical bevel gear)

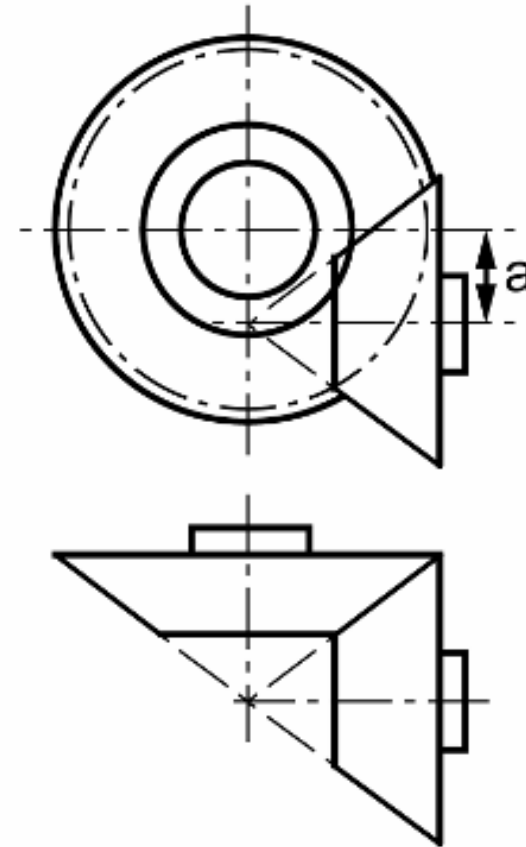

Bevel gear axle drive  
(hypoid bevel gear)

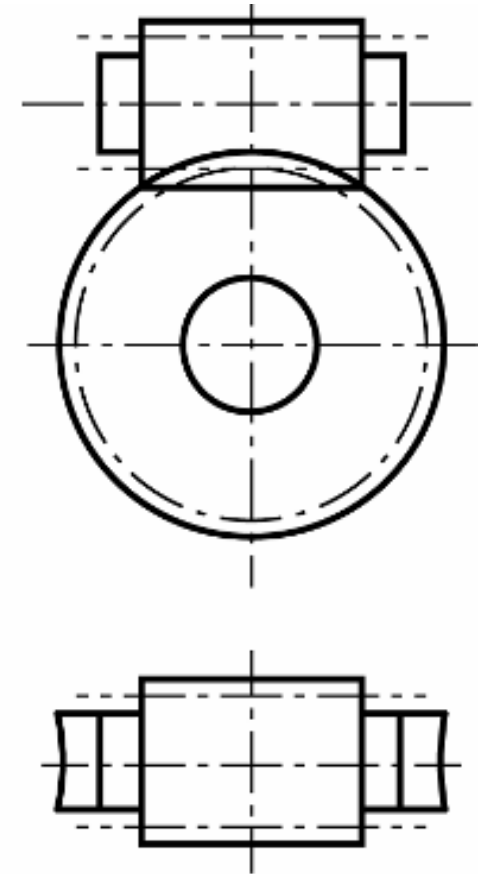

Worm gear  
axle drive

# Final Drives

## *Spur gear*

- Spur gear axle drives are now common because of the popularity of vehicles with transverse front-mounted engines.
- The axle drive is driven either directly by the output shaft of the transmission, or by idler gears
- It is normally favourable for the differential cage drive if the engine and transmission are mounted side by side, with the disadvantage of having drive shafts of unequal length to the wheels.
- The reasons for their popularity are the compactness and low production cost of spur gears, normally helical cut.

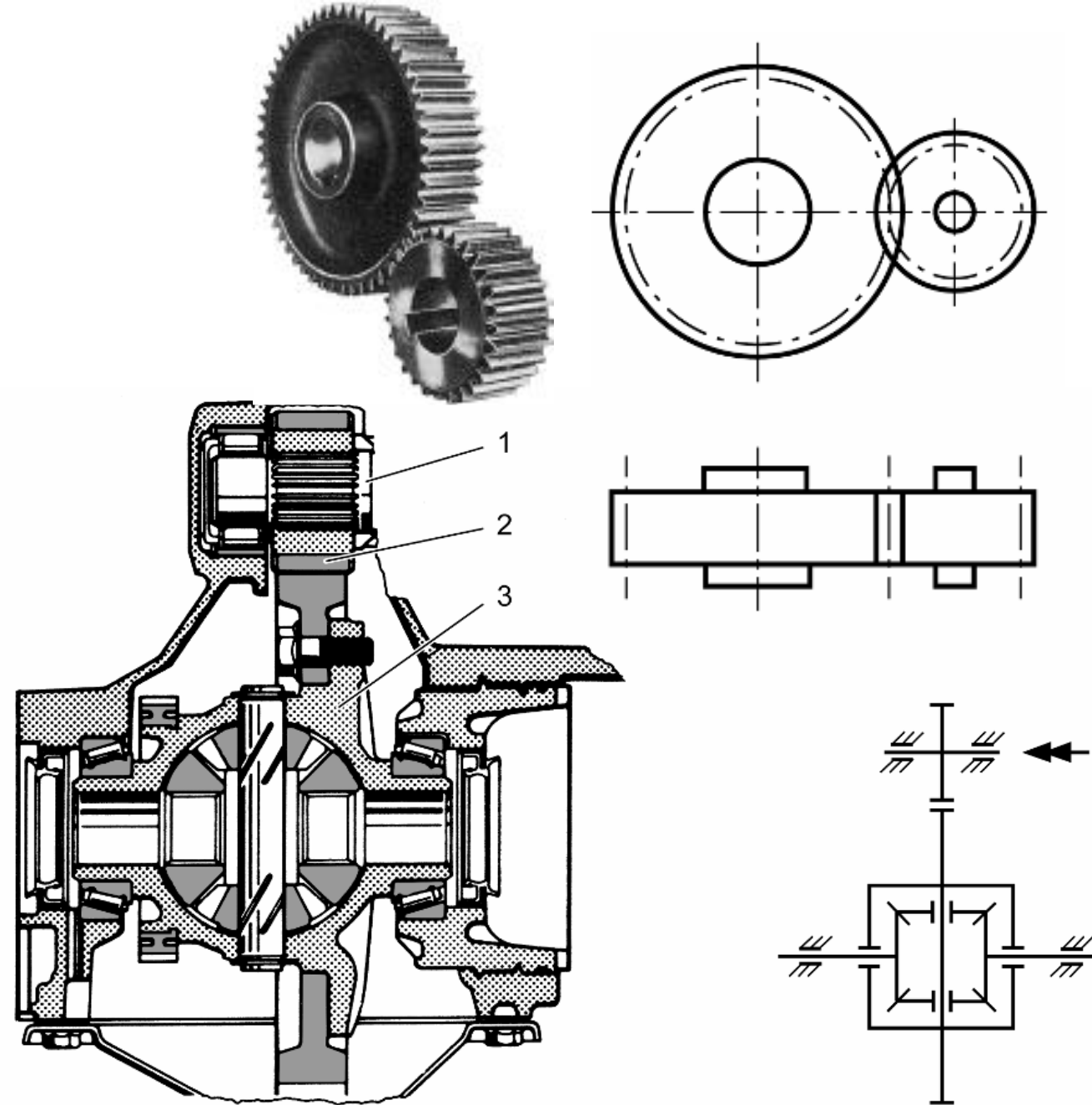

# Final Drives

## *Bevel gear*

- In powertrains where the engine is longitudinally mounted, and in all-wheel drives, the power flow to the wheels has to be turned through 90°.
- The axle drive can be integrated in the transmission housing (transaxle design), or designed as an independent assembly, as in vehicles with standard drive
- In passenger cars, **hypoid drives** are usually used, in which the bevel drive pinion engages below the axial centre of the crown gear.
- This offset makes the diameter of the bevel drive pinion larger, and the crown gear can be smaller for the same load than in helical bevel drives in which the axes intersect.
- The offset also enables the propeller shaft to be mounted lower, reducing the size of the transmission tunnel

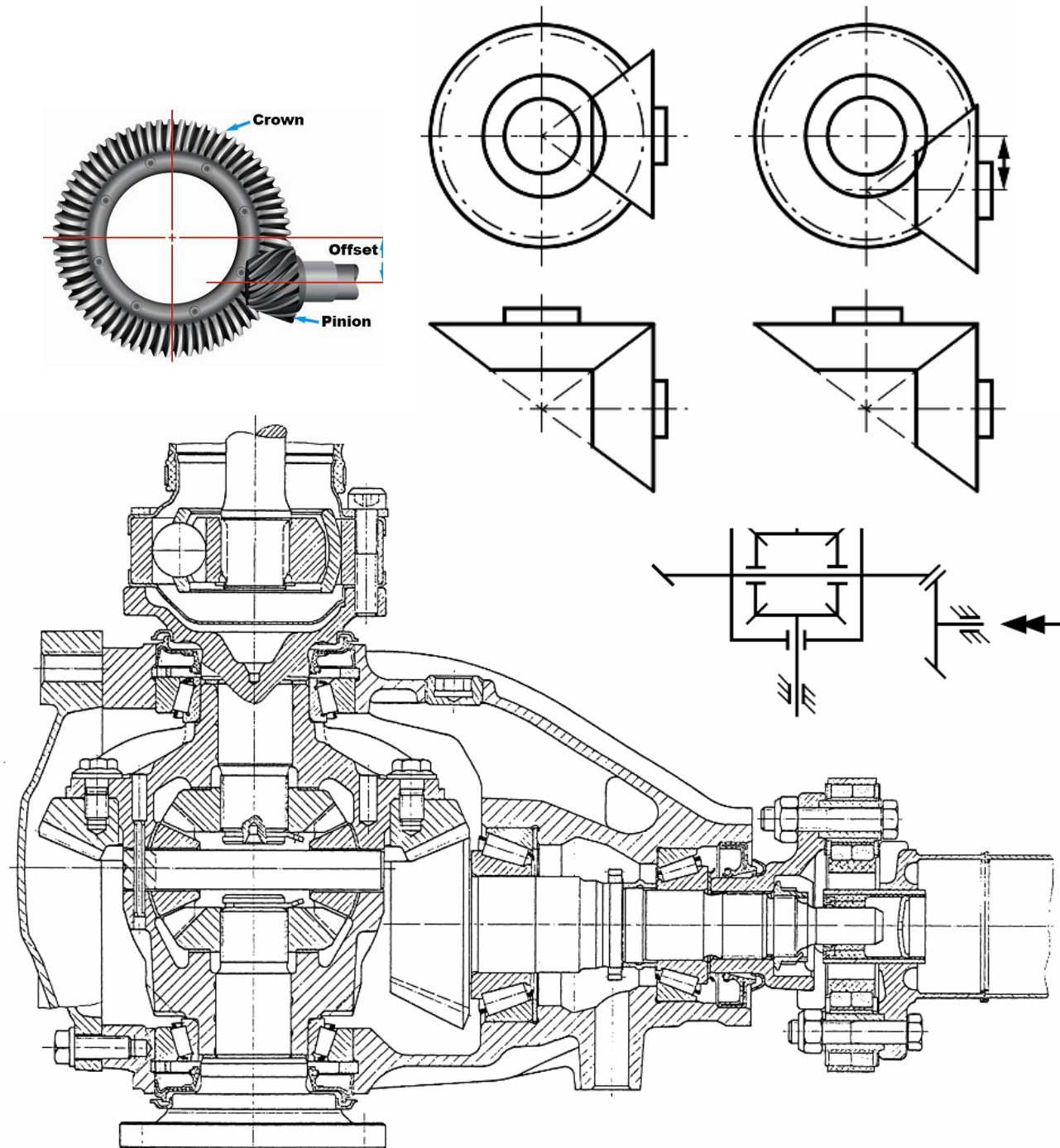

# Final Drives

## *Worm Gear Axle Drive*

***There are now no more axle drives with worm gear axle drive in production. This type of drive was used in some Peugeot models in the 1970s.***

- The worm gear axle drive does have significant advantages.
- It offers large multiplications in a compact space
- The worm can be located below or above the worm gearwheel
- Mounting the worm above the gearwheel gives the vehicle good ground clearance, a particular advantage for off-road vehicles.

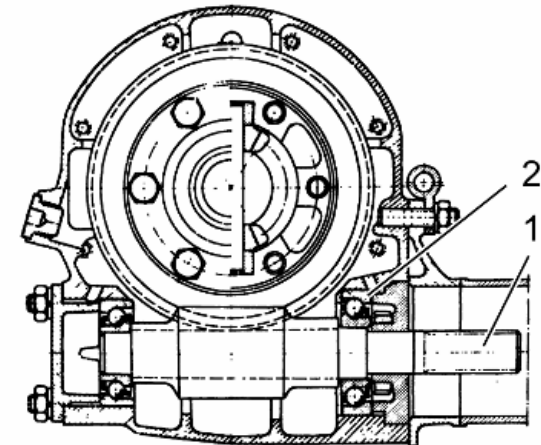
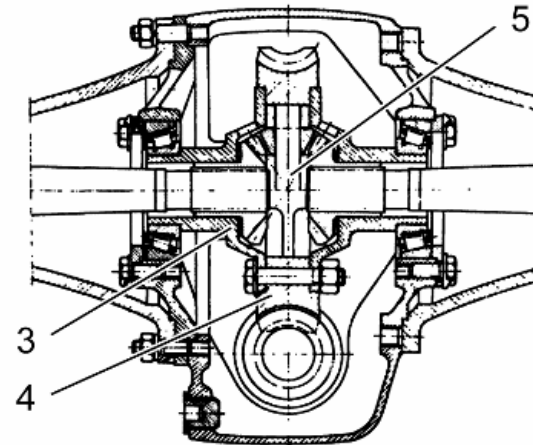
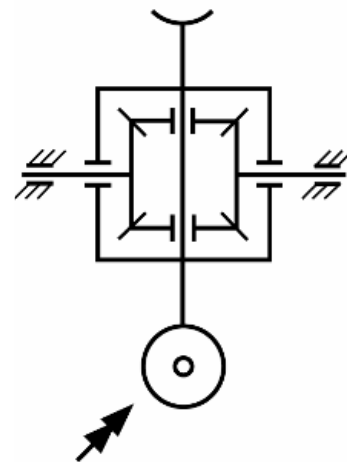
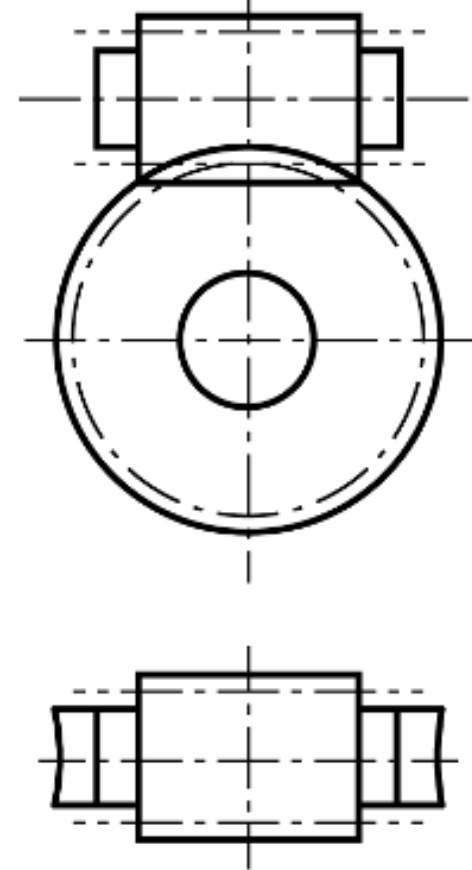

# Differential

- Working principal:
  - If both crown wheels , connected by half axle with wheels, are rotating with this same speed the plant does not rotate and thus the differential does not operate.
  - The power drive is provided to the wheels as their would be connected with each other by rigid axle. This would only happened when the car drives straight and the dynamic radius index of both wheels is the same.
  - In reality this is practically impossible .

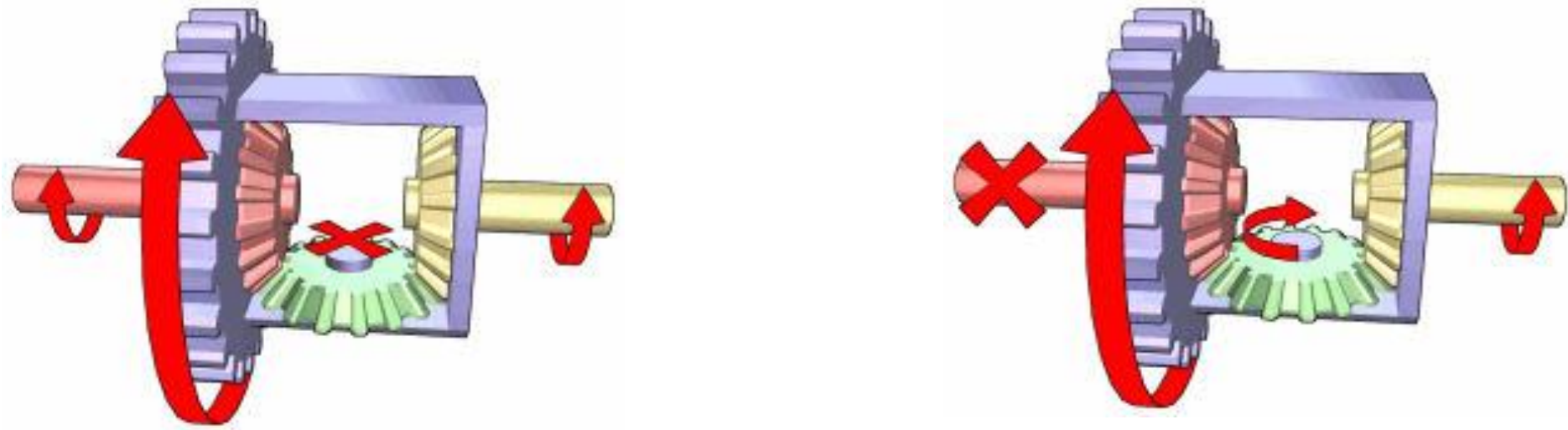



# Moment transferred by half axis

- Considering frictional moment of the differential mechanism  $M_T$ , then the moments of both half axis  $M_1$  and  $M_2$  can be described as:

$$\begin{cases} M_1 = 0,5M_0 - M_T \\ M_2 = 0,5M_0 + M_T \end{cases}$$

$$M_1 = M_2 = 0,5M_0$$

- Subtracting  $M_1 - M_2$ :

$$M_1 - M_2 = 2M_T$$

- Or another way:

$$M_{1,2\max} = \lambda M_0$$

$$\lambda = \frac{M_{1,2\max}}{M_0} = \frac{0,5M_0 + M_T}{M_0} = 0,55 \div 0,575$$

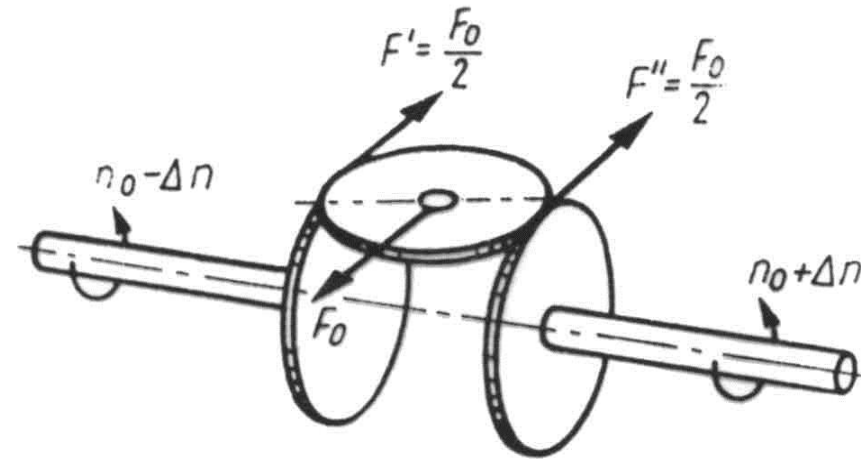

# The clutch system

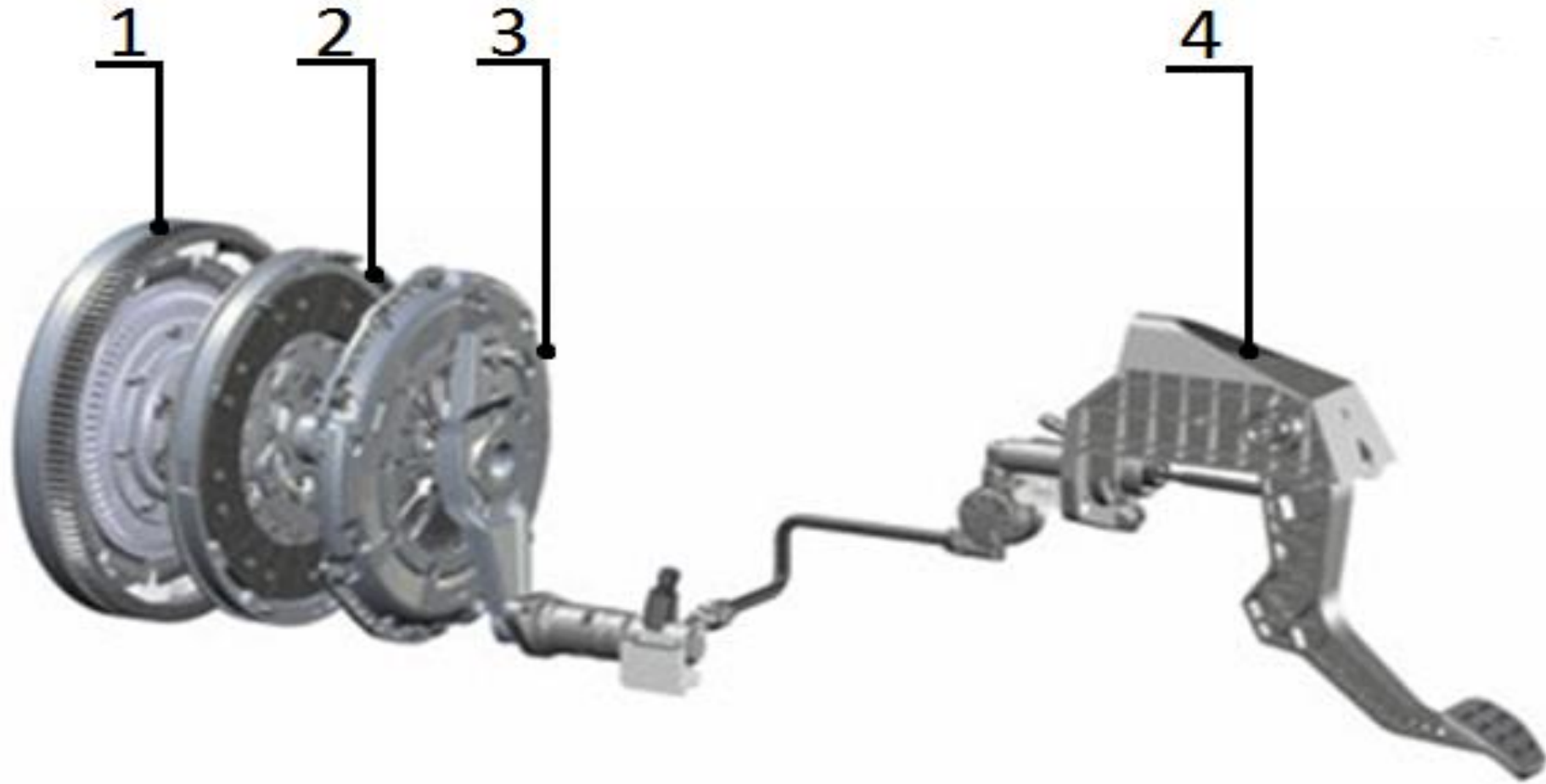

1) flywheel, 2) central disc, 3) pressure plate, 4) clutch pedal

**1/ Clutch plate:**

- a* driving plate;
- b* friction lining;
- c* cushion spring;
- d* torsion spring (driving operation);
- e* torsion spring (idle operation);
- f* friction device;
- g* hub;

**2/ pressure plate assembly:**

- h* return flat spring;
- i* pressure plate;
- j* pressure plate housing;
- k* diaphragm spring;

**3/ clutch actuation:**

- l* release bearing;
- m* sliding sleeve;
- n* release lever;

**4/ flywheel**

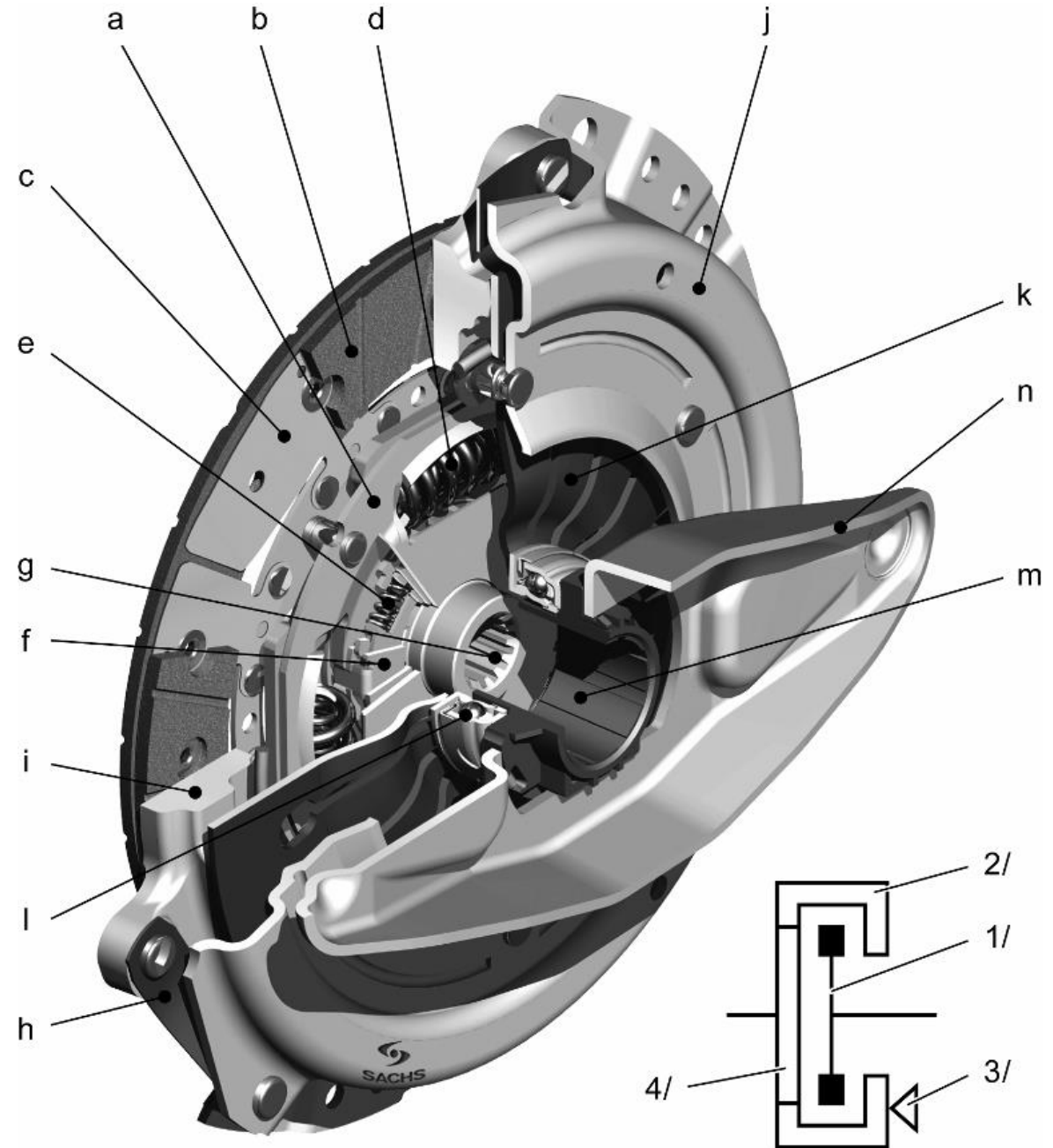

# Diaphragm clutch engaged and disengaged

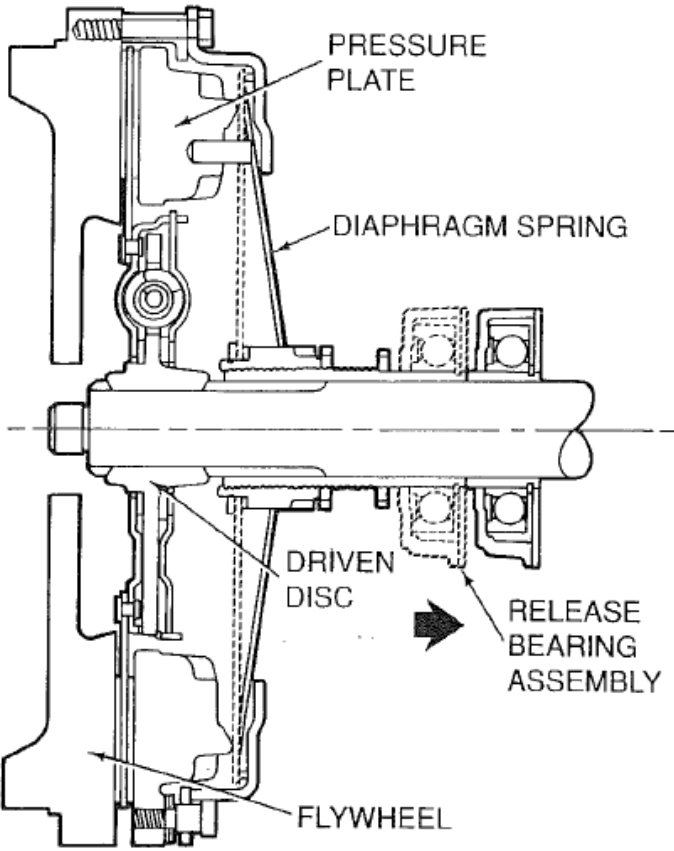
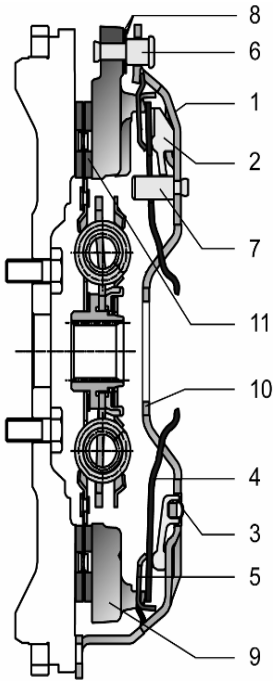
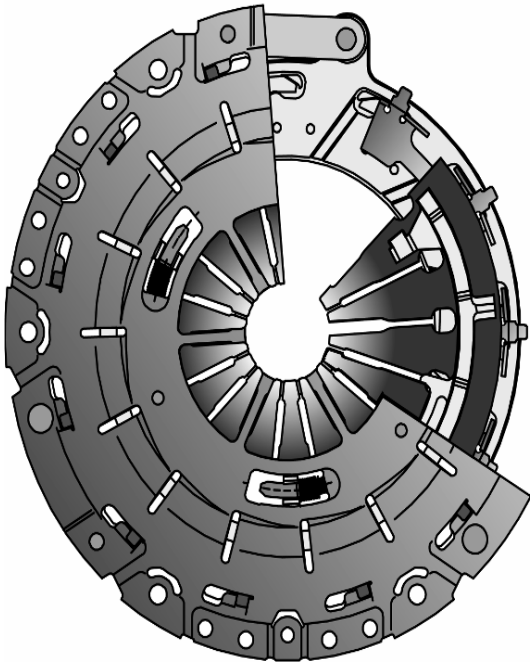

DISENGAGING THE CLUTCH

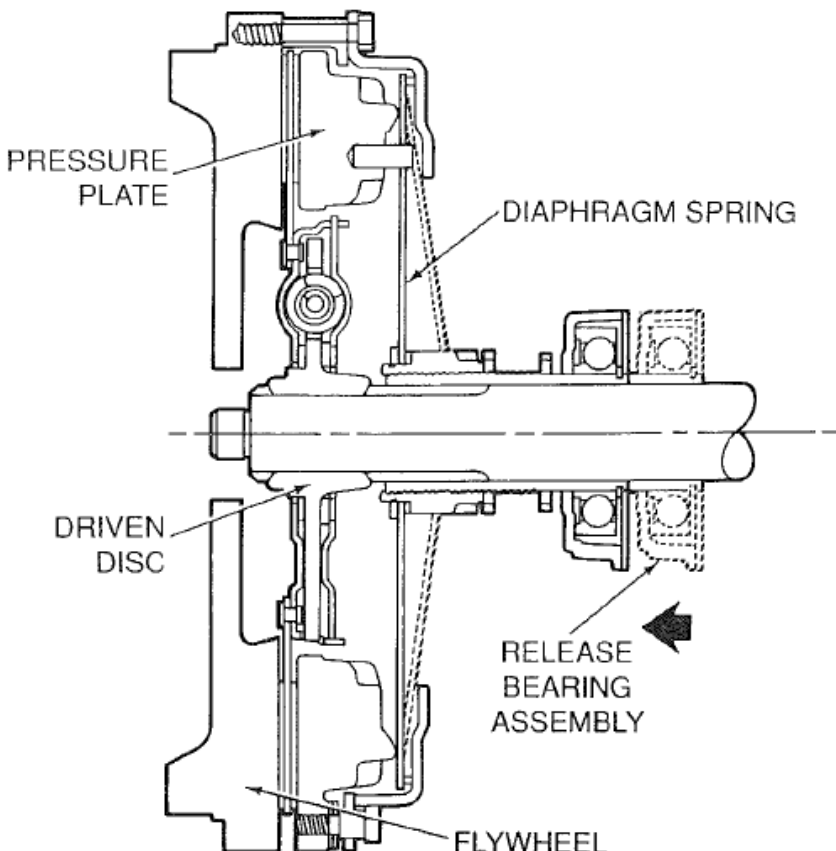

ENGAGING THE CLUTCH

- a) Clutch plate with torsion damper (passenger car);
- b) flexible clutch plate (passenger car);
- c) rigid clutch plate (passenger car);
- d) clutch plate with torsion dampers (commercial vehicle);
- e) clutch plate with cerametallic lining pads (commercial vehicle)

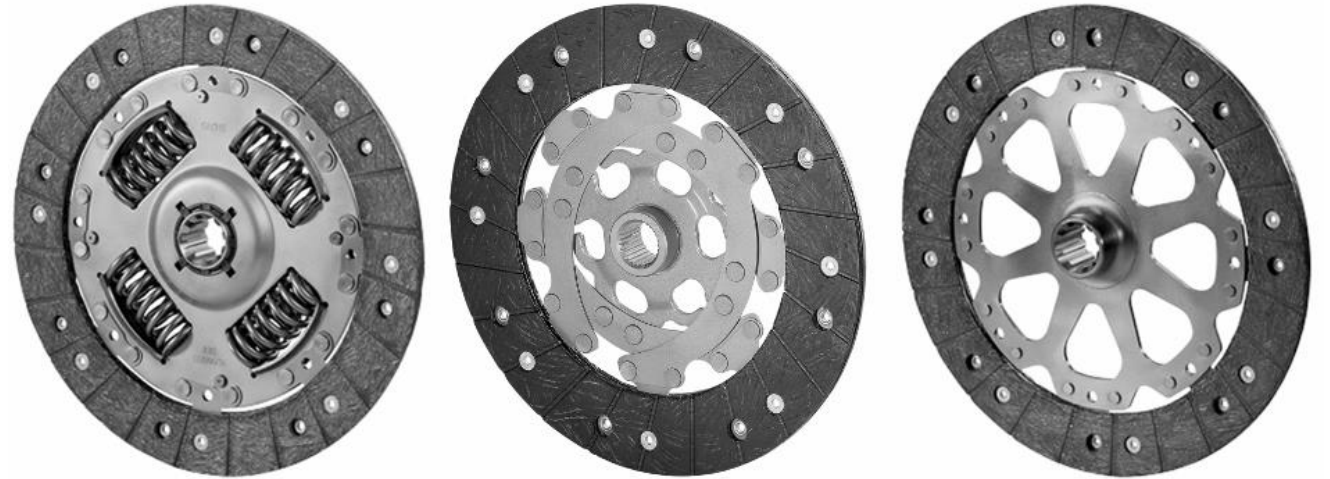

a)

b)

c)



d)



e)

## Literature

CROLLA, D. 2009. *Automotive Engineering e-Mega Reference*, Elsevier Science.

GARRETT, T. K., NEWTON, K. & STEEDS, W. 2000. *Motor Vehicle*, Elsevier Science.

HEISLER, H. 2002. *Advanced Vehicle Technology*, Butterworth-Heinemann.

NUNNEY, M. 2015. *Light and Heavy Vehicle Technology*, Routledge.

WONG, J. Y. 2001. *Theory of Ground Vehicles*, Wiley.



